

## PROVEN PERFORMANCE

Customers in over 60 countries and in diverse markets and sectors.



HMI  
Touch Screen

## Kinco HMI Catalog

- GREEN Series
- FUTURE Series
- MASS Series
- Industry Specialized Application Series



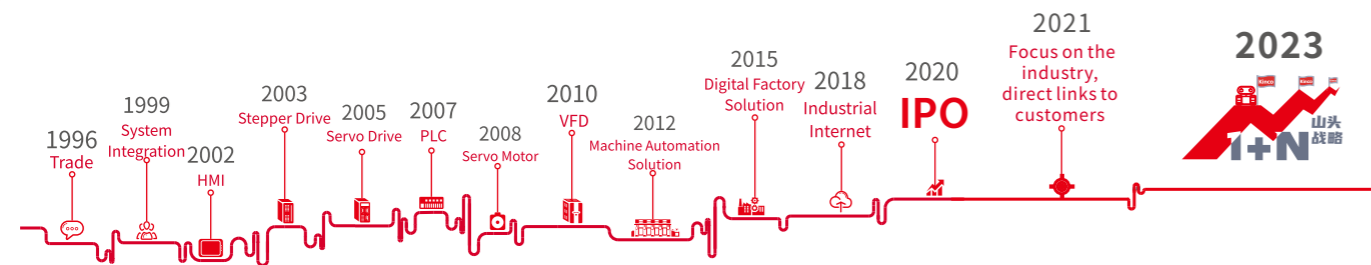

Kinco Automation (Shanghai) Co., Ltd. has always focused on the R&D, production and sales of core components for industrial automation equipment control and hardware/software products for IIoT/Internet as well as related technical services. We provide equipment automation control, digital factory and industrial Internet solutions for customers. Our company is one of the few providers of Machine Automation and Intelligent Factory Intellectualization Solutions in China.

Our core components for industrial automation equipment control mainly include industrial HMI, servo system, step system, programmable logic controller and frequency converter, and are widely used in robot, logistics equipment, packaging equipment, food equipment, clothing equipment, medical equipment, environmental protection equipment, rail transit equipment, new energy equipment and other automation equipment industries. Our hardware/software products for IIoT/Internet mainly include on-site intelligent terminal, gateway, data acquisition unit, SaaS and data center, and are mainly applied to digital factory construction and production-marketing collaborative manufacturing in food and other industries. With intelligent manufacturing as the strategic development direction, we develop the core technologies for industrial automation and factory digitization ceaselessly and unremittingly. With focus on the deep link between the industry and customers, we provide innovative, high-quality and low-cost automation/digitalization solutions. After years of continuous R&D and innovation, we have had control, drive, human-machine interaction, communication, mechanical-electrical integrated design and other automation technologies, MES, WMS and other information technologies as well as equipment data acquisition, M-IoT, industrial SaaS and other innovative technologies. We focus on the industry and continuously create value for customers. With the help of our innovative automation and intellectualization solutions, customers have effectively improved their production and management efficiency as well as product quality and production intellectualization level. In particular, we lead innovation in robot, intelligent logistics, medical imaging equipment, new energy equipment, machine tool accessory, digital food factory and other fields. We take "Let Chinese manufacturing become the top of the world" as the mission and "Intelligent makes better life" as the vision, uphold the value of "Grow Conscientiously, Innovate ingeniously", and adhere to the innovative thinking and down-to-earth attitude when developing products and carrying on businesses, insist on the ideal, and expect that human creativity can make the world more beautiful.

CONTENTS

**GREEN Series Description**

03 Series Description

**Enhanced Type**

- 07 GH043/GH043E
- 08 GH043U2/GH043EU2
- 09 GH070/GH070E
- 10 GH104E
- 11 GH150E

**Standard Type**

- 12 G070/G070E/G070E-CAN
- 13 G100/G100E
- 14 G121E
- 15 G121HE

**Economy Type**

- 16 GL043/GL043E
- 17 GL070/GL070E
- 18 GL100/GL100E
- 19 GL104E
- 20 GL150E

**IoT Type**

- 21 GT070HE/GT070HE-4G/GT070HE-WiFi
- 22 GT070E2
- 23 GT100E/GT100E-4G/GT100E-WiFi
- 24 GT100E1
- 25 GT100E2/GT100E2-WiFi  
/GT100E2-4G/GT100E2-CAN
- 26 GT121E
- 27 GT150E2
- 28 GW01/GW01-4G/GW01-WiFi

**FUTURE Series Description**

29 Series Description

**FUTURE Series**

- 30 F070E
- 31 F080E
- 32 F104E/F104E-CAN
- 33 F121E
- 34 F121EW
- 35 F150E
- 36 F150EW
- 37 xF-SiHMI01

**MASS Series**

- 38 M2070H/M2070HE
- 39 M2100/M2100E

**Industry Specialized Application Series**

- 40 Rear-installation without front shell:  
GR Series: GR043/GR070E/GR100E
- 41 Economy Handheld Terminal: RT070
- 42 Handheld Terminal:  
SZ7G/SZ7GS/SZ7GE/SZ7GES
- 43 Engineering Machinery: CZ6
- 44 Waterproof Dedicated: F10N
- 45 Waterproof Dedicated: G100E-LRF
- 46 Wide temperature HMI: G100E2-WiFi-PR01

**Features of Dtools (configuration software)**

# Teleservice

— A value adding IoT function for OEMs

Teleservice based on Kinco Edgeaccess (IoT platform) is tailored for OEMs.

**Advantages:**

Easy to set up, low-cost, safe and reliable, covering multi-scenario service needs of OEMs.

**Applications:**

- Remote desktop: Remotely monitor the machine in real time;
- Remote download: Remotely download HMI and PLC programs;
- Remote expert-level diagnosis: Debug HMI and PLC programs online;
- Online update: Remotely implant new recipe.

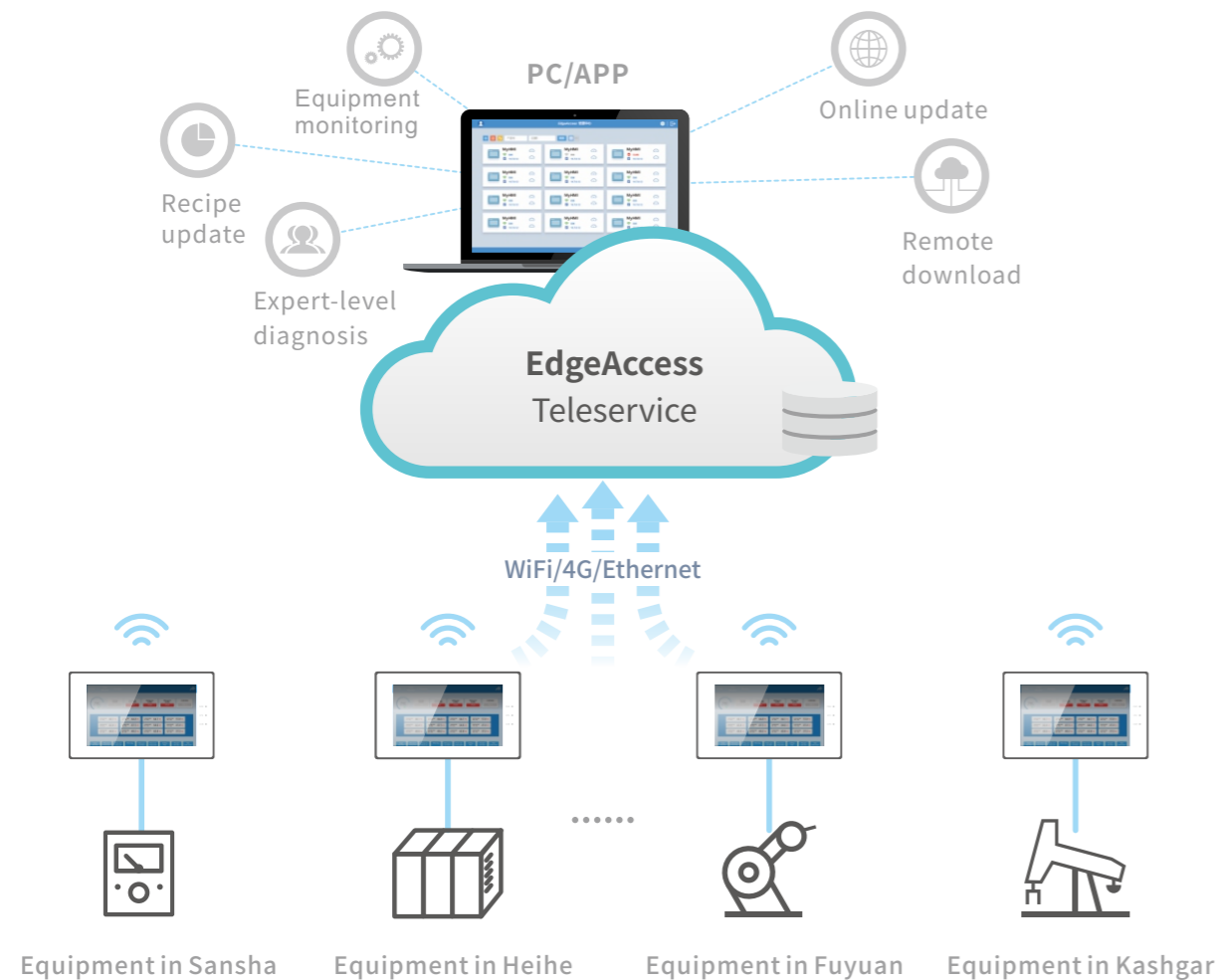

# Easy docking with Kinco M-IoT

— Help you open a new era of industrial Internet

HMI Cloud Solutions help devices make connections for efficient and convenient information interaction between devices and cloud, devices and devices as well as devices and people.

- View their operating status in real time
- Acquire data to assist with data analysis, product optimization and pre-maintenance
- Receive their fault alarms in real time
- Cost saving and no extra investment cost

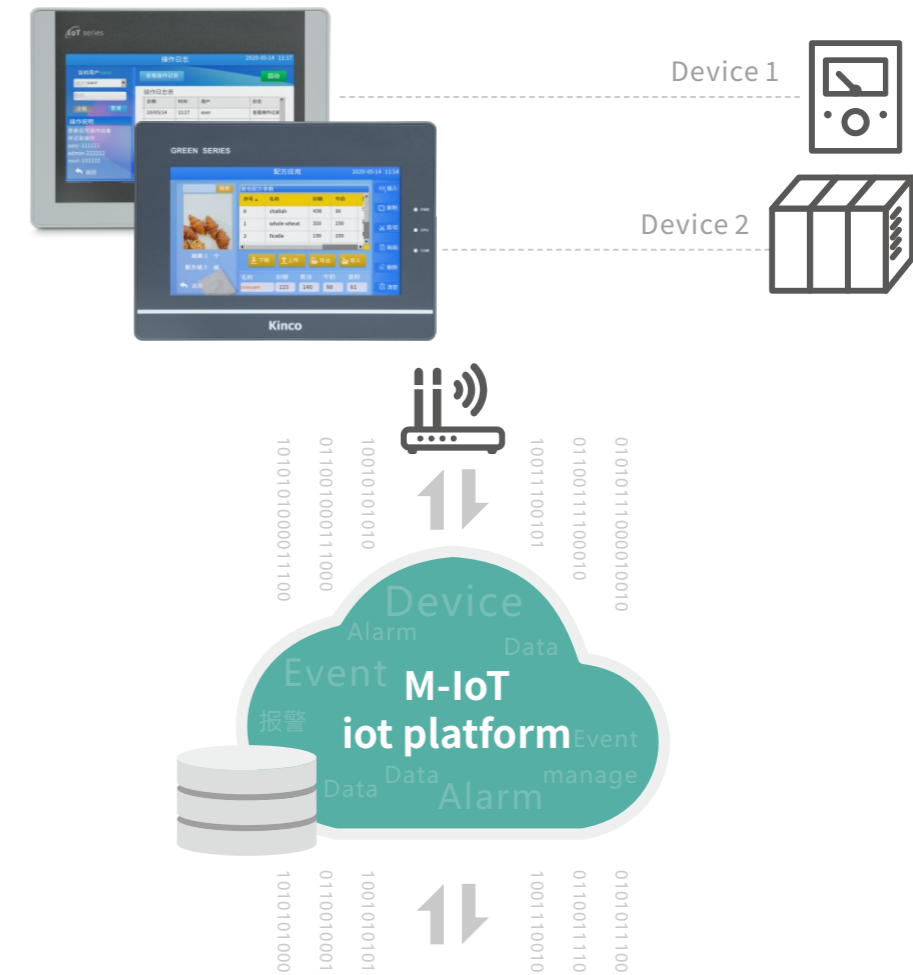

\*All models with Ethernet ports in this Document support this function.

# With focus on industrial HMIs for 21 years, we consistently provide high-quality products

The GREEN series products, as a new generation of industrial HMIs launched by Kinco, adopt new architecture design and obtain rigorous craft support, to become the paradigms of high-quality HMIs.

The GREEN series HMIs adopt the mainstream processors in the market. Not only does it ensure the products' life cycle, but it also greatly improves the products' performance.



## Powerful hardware and software More comprehensive upgrades

### Structure

New structure & exquisite body

### Material

Higher hardness and intensity  
Higher temperature resistance

### Color

16.77M true color (except for a few models)

### Kernel

Kernel version upgrades  
More stable performance

### CPU

Industrial-grade CPU  
Main frequency: 800MHz

### Memory

The memory DDR3 is upgraded to 128M

# Kinco's new generation of industrial HMI GREEN Series

The GREEN series products use the most advantageous ARM Cortex-A7 architecture industrial-grade processors, which ensure that HMIs efficiently work.

Kinco's advanced smart factory provides reliable guarantee for high-quality production in long term. The GREEN series products fully help improve the quality of high-end manufacturing equipment in China.

## GREEN series contains multiple subseries:

**GH Series**  
Enhanced Type  
All 4.3"-15" models

- Up to 4 serial ports (excluding 4.3"), Ethernet
- Standard configuration: USB master port and slave port
- With built-in isolated power supply, some models support serial port isolation
- Three-proofing coating of mainboard

**G Series**  
Standard Type  
7", 10" and 12" models

- 3 serial ports, Ethernet
- Standard configuration: USB master port and slave port
- Built-in isolated power supply
- Three-proofing coating of mainboard

**GL Series**  
Economy type  
All 4.3"-15" models

- 2 serial ports, Ethernet
- Standard configuration: USB master port and slave port (excluding 4.3")

**GT/GW Series**  
IoT type  
7", 10.1", 12.1", 15", Gateway

- Support WIFI, 4G and Ethernet

# Enhanced Type

GH Series 4.3"

## GH043/GH043E

- Preferred models for subway, high-speed railway and other rail transit
- Three-proofing coating of mainboard to effectively deal with complex environment
- Built-in isolated power supply to enhance reliability
- Classic shape, hidden serial port outlet



Model/Specification	GH043	GH043E	Mechanical Dimensions (Unit: mm)
<b>Performance specifications</b>			
Display size	4.3" TFT		
Display area	95.04(W)x53.86(H)		
Resolution	480*272 pixels		
Display color	16.77M true color		
Display angle of view	70/70/50/70 (left/right/up/down)		
Contrast ratio	500:1		
Backlight	LED		
Brightness	300cd/m <sup>2</sup>		
Backlight life	More than 30,000 hours		
Touch panel	4-wire precision resistance network (surface hardness: 4H)		
Processor	ARM RISC 32Bit 800MHz		
Storage	256 MB NAND Flash Memory + 128 MB DDR.3 Memory		
RTC	Built-in		
Expandable storage	1 USB Host	1 USB Host + 1 SD Card	
Print port	USB host/serial port	USB host/serial port	
Ethernet	None	LAN0:10/100Mbps	
Program download	USB Slave (Type B)/U disk	USB Slave (Type B)/U disk/Ethernet port	
Communication port	COM0:RS232/RS485/RS422 COM2:RS232		
Serial port isolation	None		
<b>Electrical specifications</b>			
Input power supply	DC10.8V~DC28V, built-in isolated		
Power consumption	3.5W@DC24V		
Allowable loss of power	<3ms		
Insulation resistance	Over 50MΩ@500V DC		
Hi-pot test	500 VAC 1 minute		
<b>Structure specifications</b>			
PCB coating (Yes/No)	Yes		
Shell material	Engineering plastic		
Shape size	154×89×60mm		
Cutout size	146×81 mm		
Weight	0.4kg		
<b>Environmental specifications</b>			
Operating ambient temperature	-20~55°C		
Operating ambient humidity	10~90% RH (noncondensing)		
Storage ambient temperature	-25~60°C		
Storage ambient humidity	10~90% RH (noncondensing)		
Sine vibration test	10~500Hz, 30m/S <sup>2</sup> , X, Y, Z directions/hour		
Cooling mode	Natural air cooling		
<b>Product certification</b>			
Panel protection grade	IP65 compliant (4208-93)		
CE authentication	CE compliant (EN61000-6-4:2007+A1:2011, EN61000-6-2:2005)		
<b>Software</b>			
Configuration software	Kinco DTools V4.1 and above		

Note: GH043 is replacement of MT4210T; GH043E is replacement of MT4220TE.

# Enhanced Type

GH Series 4.3"

## GH043U2/GH043EU2

- Preferred models for subway, high-speed railway and other rail transit
- Three-proofing coating of mainboard to effectively deal with complex environment
- Built-in isolated power supply to enhance reliability
- Designed with dual USB hosts, both front and rear can be connected to one USB interface device or U disk



Model/Specification	GH043U2	GH043EU2	Mechanical Dimensions (Unit: mm)
<b>Performance specifications</b>			
Display size	4.3" TFT		
Display area	95.04(W)x53.86(H)		
Resolution	480*272 pixels		
Display color	16.77M true color		
Display angle of view	70/70/50/70 (left/right/up/down)		
Contrast ratio	500:1		
Backlight	LED		
Brightness	300cd/m <sup>2</sup>		
Backlight life	More than 30,000 hours		
Touch panel	4-wire precision resistance network (surface hardness: 4H)		
Processor	ARM RISC 32Bit 800MHz		
Storage	256 MB NAND Flash Memory + 128 MB DDR.3 Memory		
RTC	Built-in		
Expandable storage	2 USB Host	2 USB Host+1 SD Card	
Print port	USB host*2/serial port	USB host*2/serial port	
Ethernet	None	LAN0:10/100Mbps	
Program download	USB Slave (Type B)/U disk	USB Slave (Type B)/U disk/Ethernet port	
Communication port	COM0:RS232/RS485/RS422 COM2:RS232		
Serial port isolation	None		
<b>Electrical specifications</b>			
Input power supply	DC10.8V~DC28V, built-in isolated		
Power consumption	3.5W@DC24V		
Allowable loss of power	<3ms		
Insulation resistance	Over 50MΩ@500V DC		
Hi-pot test	500 VAC 1 minute		
<b>Structure specifications</b>			
PCB coating (Yes/No)	Yes		
Shell material	Engineering plastic		
Shape size	154×89×60mm		
Cutout size	146×81 mm		
Weight	0.4kg		
<b>Environmental specifications</b>			
Operating ambient temperature	-20~55°C		
Operating ambient humidity	10~90% RH (noncondensing)		
Storage ambient temperature	-25~60°C		
Storage ambient humidity	10~90% RH (noncondensing)		
Sine vibration test	10~500Hz, 30m/S <sup>2</sup> , X, Y, Z directions/hour		
Cooling mode	Natural air cooling		
<b>Product certification</b>			
Panel protection grade	IP65 compliant (4208-93)		
CE authentication	CE compliant (EN61000-6-4:2007+A1:2011, EN61000-6-2:2005)		
<b>Software</b>			
Configuration software	Kinco DTools V4.1 and above		

# Enhanced Type

GH Series 7"

## GH070/GH070E

- Suitable for high reliability expected situations
- Three-proofing coating + multiple isolation, more reliable
- Up to four serial ports + SD card expansion
- Artistically ultra-narrow border



Model/Specification	GH070	GH070E
<b>Performance specifications</b>		
Display size	7" TFT	
Display area	154.08(W)x85.92(H)	
Resolution	800*480 pixels	
Display color	16.77M true color	
Display angle of view	70/70/50/70 (left/right/up/down)	
Contrast ratio	500:1	
Backlight	LED	
Brightness	400cd/m <sup>2</sup>	
Backlight life	More than 30,000 hours	
Touch panel	4-wire precision resistance network (surface hardness: 4H)	
Processor	ARM RISC 32Bit 800MHz	
Storage	256 MB NAND Flash Memory + 128 MB DDR.3 Memory	
RTC	Built-in	
Expandable storage	1 USB Host	1 USB Host + 1 SD Card
Print port	USB host/serial port	USB host/serial port
Ethernet	None	LAN0:10/100Mbps
Program download	USB Slave (Type B)/U disk	USB Slave (Type B)/U disk/Ethernet port
Communication port	COM0:RS232/RS485/RS422 COM1:RS232/RS485/RS422 COM2:RS232/RS485/RS422	
Serial port isolation	None	Built-in
<b>Electrical specifications</b>		
Input power supply	DC12V~DC28V, built-in isolated	
Power consumption	5W@DC24V	
Allowable loss of power	<3ms	
Insulation resistance	Over 50MΩ@500V DC	
Hi-pot test	500 VAC 1 minute	
<b>Structure specifications</b>		
PCB coating (Yes/No)	Yes	
Shell material	Engineering plastic	
Shape size	207×125×41mm	
Cutout size	194×113mm	
Weight	0.6kg	
<b>Environmental specifications</b>		
Operating ambient temperature	-10~55°C	
Operating ambient humidity	10~90% RH (noncondensing)	
Storage ambient temperature	-20~60°C	
Storage ambient humidity	10~90% RH (noncondensing)	
Sine vibration test	10~500Hz, 30m/S <sup>2</sup> , X, Y, Z directions/hour	
Cooling mode	Natural air cooling	
<b>Product certification</b>		
Panel protection grade	IP65 compliant (4208-93)	
CE authentication	CE compliant (EN61000-6-4:2007+A1:2011, EN61000-6-2:2005)	
<b>Software</b>		
Configuration software	Kinco DTools V4.1 and above	

Mechanical Dimensions (Unit: mm)

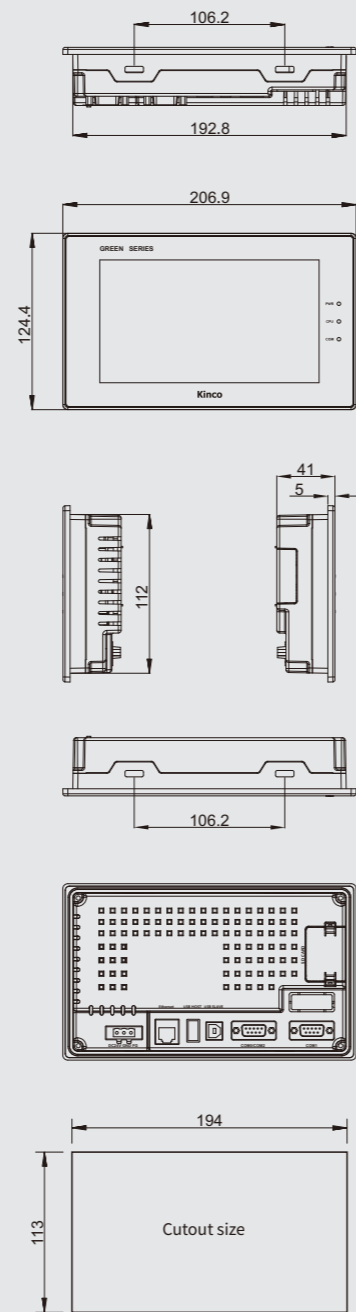

# Enhanced Type

GH Series 10.4"

## GH104E

- Suitable for high reliability expected situations
- Three-proofing coating + multiple isolation, more reliable
- Up to four serial ports + SD card expansion
- Industrial size



Model/Specification	GH104E
<b>Performance specifications</b>	
Display size	10.4" TFT
Display area	211.20(W)x158.40(H)
Resolution	800*600 pixels
Display color	16.77M true color
Display angle of view	70/70/60/70 (left/right/up/down)
Contrast ratio	500:1
Backlight	LED
Brightness	350cd/m <sup>2</sup>
Backlight life	More than 30,000 hours
Touch panel	4-wire precision resistance network (surface hardness: 4H)
Processor	ARM RISC 32Bit 800MHz
Storage	256 MB NAND Flash Memory + 128 MB DDR.3 Memory
RTC	Built-in
Expandable storage	1 USB Host+1 SD Card
Print port	USB host/serial port
Ethernet	LAN0:10/100Mbps
Program download	USB Slave (Type B)/U disk
Communication port	COM0:RS232/RS485/RS422 COM1:RS232/RS485/RS422 COM2:RS232, COM3:RS485
Serial port isolation	Built-in
<b>Electrical specifications</b>	
Input power supply	DC10.8V~DC28V, built-in isolated
Power consumption	8W@DC24V
Allowable loss of power	<3ms
Insulation resistance	Over 50MΩ@500V DC
Hi-pot test	500 VAC 1 minute
<b>Structure specifications</b>	
PCB coating (Yes/No)	Yes
Shell material	Engineering plastic
Shape size	310×230×56mm
Cutout size	299×219mm
Weight	1.715kg
<b>Environmental specifications</b>	
Operating ambient temperature	-10~55°C
Operating ambient humidity	10~90% RH (noncondensing)
Storage ambient temperature	-20~60°C
Storage ambient humidity	10~90% RH (noncondensing)
Sine vibration test	10~500Hz, 30m/S <sup>2</sup> , X, Y, Z directions/hour
Cooling mode	Natural air cooling
<b>Product certification</b>	
Panel protection grade	IP65 compliant (4208-93)
CE authentication	CE compliant (EN61000-6-4:2007+A1:2011, EN61000-6-2:2005)
<b>Software</b>	
Configuration software	Kinco DTools V4.1 and above

Mechanical Dimensions (Unit: mm)

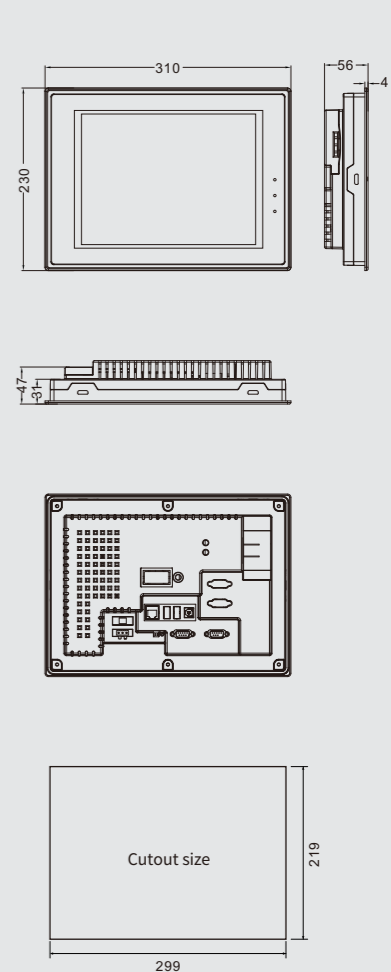

Note: GH070 is the replacement model of MT4404T and MT4424T; The GH070E is a replacement for MT4404TE and MT4424TE.

Note: GH104E is replacement of MT4523TE and MT4523T.

# Enhanced Type

GH Series 4.3"

## GH150E

- Suitable for high reliability expected situations
- Three-proofing coating + multiple isolation, more reliable
- Up to four serial ports + SD card expansion
- Compact body, elegant appearance



Model/Specification	GH150E
<b>Performance specifications</b>	
Display size	15" TFT
Display area	304.13(W)x228.10(H)
Resolution	1,024*768 pixels
Display color	65,536 color
Display angle of view	80/80/80/80 (left/right/up/down)
Contrast ratio	800:1
Backlight	LED
Brightness	420cd/m <sup>2</sup>
Backlight life	50,000 hours
Touch panel	4-wire precision resistance network (surface hardness: 4H)
Processor	ARM RISC 32Bit 800MHz
Storage	256 MB NAND Flash Memory + 128 MB DDR.3 Memory
RTC	Built-in
Expandable storage	1 USB Host+1 SD Card
Print port	USB host/serial port
Ethernet	LAN0:10/100Mbps
Program download	USB Slave (Micro USB)/U disk/Ethernet port
Communication port	COM0:RS232/RS485/RS422 COM1:RS232/RS485/RS422 COM2:RS232, COM3:RS485
Serial port isolation	Built-in
<b>Electrical specifications</b>	
Input power supply	DC10.8V~DC28V, built-in isolated
Power consumption	16W@DC24V
Allowable loss of power	<3ms
Insulation resistance	Over 50MΩ@500V DC
Hi-pot test	500 VAC 1 minute
<b>Structure specifications</b>	
PCB coating (Yes/No)	Yes
Shell material	Engineering plastic
Shape size	398×298×47mm
Cutout size	383×283mm
Weight	3kg
<b>Environmental specifications</b>	
Operating ambient temperature	-10~55°C
Operating ambient humidity	10~90% RH (noncondensing)
Storage ambient temperature	-20~60°C
Storage ambient humidity	10~90% RH (noncondensing)
Sine vibration test	10~500Hz, 30m/S <sup>2</sup> , X, Y, Z directions/hour
Cooling mode	Natural air cooling
<b>Product certification</b>	
Panel protection grade	IP65 compliant (4208-93)
CE authentication	CE compliant (EN61000-6-4:2007+A1:2011, EN61000-6-2:2005)
<b>Software</b>	
Configuration software	Kinco DTools V4.1 and above

Mechanical Dimensions (Unit: mm)

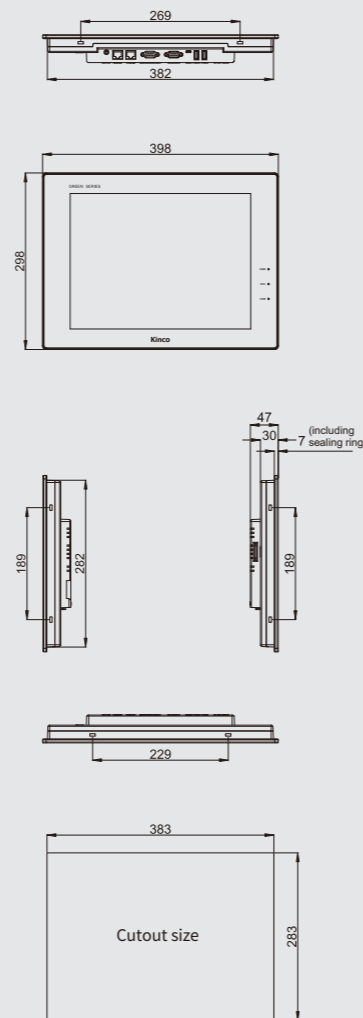

Note: GH150E is replacement of MT4720TE.

# Standard Type

GH Series 7"

## G070/G070E/G070E-CAN

- Three-proofing coating + built-in isolated power supply to enhance reliability
- High brightness LCD provides a better display effect
- Support CAN bus
- Three serial ports for meeting diverse needs



Model/Specification	G070	G070E	G070E-CAN
<b>Performance specifications</b>			
Display size	7" TFT		
Display area	154.08(W)x85.92(H)		
Resolution	800*480 pixels		
Display color	16.77M true color		
Display angle of view	70/70/60/70 (left/right/up/down)		
Contrast ratio	500:1		
Backlight	LED		
Brightness	400cd/m <sup>2</sup>		
Backlight life	More than 30,000 hours		
Touch panel	4-wire precision resistance network (surface hardness: 4H)		
Processor	ARM RISC 32Bit 800MHz		
Storage	256 MB NAND Flash Memory + 128 MB DDR.3 Memory		
RTC	Built-in		
Expandable storage	1 USB Host		
Print port	USB host/serial port		
Ethernet	None	LAN0:10/100Mbps	LAN0:10/100Mbps
Bus port	None	None	1*CANopen
Program download	USB Slave (Micro USB)/U disk	USB Slave (Micro USB)/U disk/Ethernet port	
Communication port	COM0:RS232/RS485/RS422 COM1:RS485/RS422 COM2:RS232		
Serial port isolation	None	Built-in	
<b>Electrical specifications</b>			
Input power supply	DC12V~DC28V, built-in isolated		
Power consumption	3.8W@DC24V		
Allowable loss of power	<3ms		
Insulation resistance	Over 50MΩ@500V DC		
Hi-pot test	500 VAC 1 minute		
<b>Structure specifications</b>			
PCB coating (Yes/No)	Yes	Yes	Yes
Shell material	Engineering plastic		
Shape size	204×150×37mm		
Cutout size	192×138mm		
Weight	0.5kg		
<b>Environmental specifications</b>			
Operating ambient temperature	0~50°C		
Operating ambient humidity	10~90% RH (noncondensing)		
Storage ambient temperature	-20~60°C		
Storage ambient humidity	10~90% RH (noncondensing)		
Sine vibration test	10~500Hz, 30m/S <sup>2</sup> , X, Y, Z directions/hour		
Cooling mode	Natural air cooling		
<b>Product certification</b>			
Panel protection grade	IP65 compliant (4208-93)		
Authentication	CE compliant (EN61000-6-4:2007+A1:2011, EN61000-6-2:2005) UL compliant		
<b>Software</b>			
Configuration software	Kinco DTools V4.1 and above		

Mechanical Dimensions (Unit: mm)

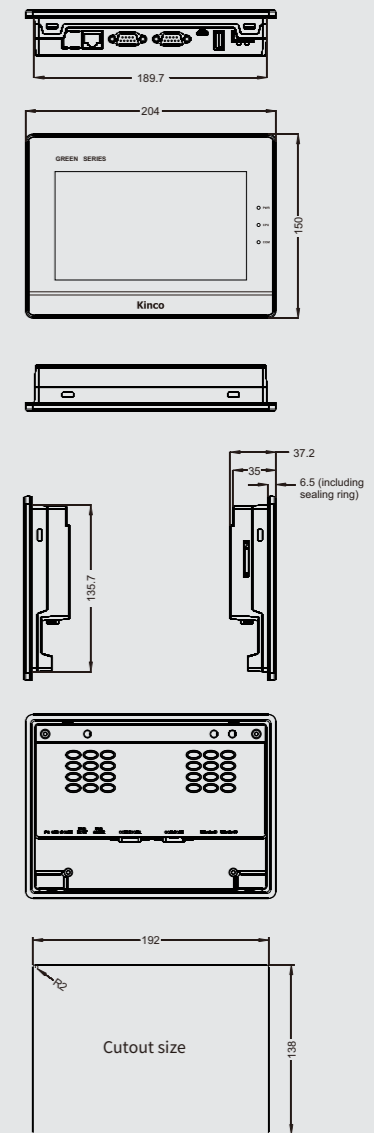

Note: G070 is replacement of MT4414T, MT4300, CMT4310, CMT5320C, MT4300T and MT5323T; G070E is replacement of MT4414TE and MT4300CE; G070E-CAN is replacement of MT4414TE-CAN.

# Standard Type

## G Series 10.1"

### G100/G100E

- Preferred model in food industry
- Three-proofing coating + built-in isolated power supply to enhance reliability
- Three serial ports for meeting diverse needs
- The high resolution 1,024\*600 meets diverse needs



Model/Specification	G100	G100E
<b>Performance specifications</b>		
Display size	10.1" TFT	
Display area	222.72(W)x125.28(H)	
Resolution	1,024*600 pixels	
Display color	16.77M true color	
Display angle of view	75/75/60/60 (left/right/up/down)	
Contrast ratio	500:1	
Backlight	LED	
Brightness	350cd/m <sup>2</sup>	
Backlight life	50,000 hours	
Touch panel	4-wire precision resistance network (surface hardness: 4H)	
Processor	ARM RISC 32Bit 800MHz	
Storage	256 MB NAND Flash Memory + 128 MB DDR.3 Memory	
RTC	Built-in	
Expandable storage	1 USB Host	
Print port	USB host/serial port	
Ethernet	None	LAN0:10/100Mbps
Program download	U disk	U disk/Ethernet port
Communication port	COM0:RS232/RS485/RS422 COM1:RS485/RS422 COM2:RS232	
<b>Electrical specifications</b>		
Input power supply	DC12V~DC28V, built-in isolated	
Power consumption	6W@DC24V	
Allowable loss of power	<3ms	
Insulation resistance	Over 50MΩ@500V DC	
Hi-pot test	500 VAC 1 minute	
<b>Structure specifications</b>		
PCB coating (Yes/No)	Yes	Yes
Shell material	Engineering plastic	
Shape size	310X230X55mm	
Cutout size	299X219mm	
Weight	1.8kg	
<b>Environmental specifications</b>		
Operating ambient temperature	-10~55°C	
Operating ambient humidity	10~90% RH (noncondensing)	
Storage ambient temperature	-20~60°C	
Storage ambient humidity	10~90% RH (noncondensing)	
Sine vibration test	10~500Hz, 30m/S <sup>2</sup> , X, Y, Z directions/hour	
Cooling mode	Natural air cooling	
<b>Product certification</b>		
Panel protection grade	IP65 compliant (4208-93)	
CE authentication	CE compliant (EN61000-6-4:2007+A1:2011, EN61000-6-2:2005)	
<b>Software</b>		
Configuration software	Kinco DTools V4.1 and above	

Mechanical Dimensions (Unit: mm)

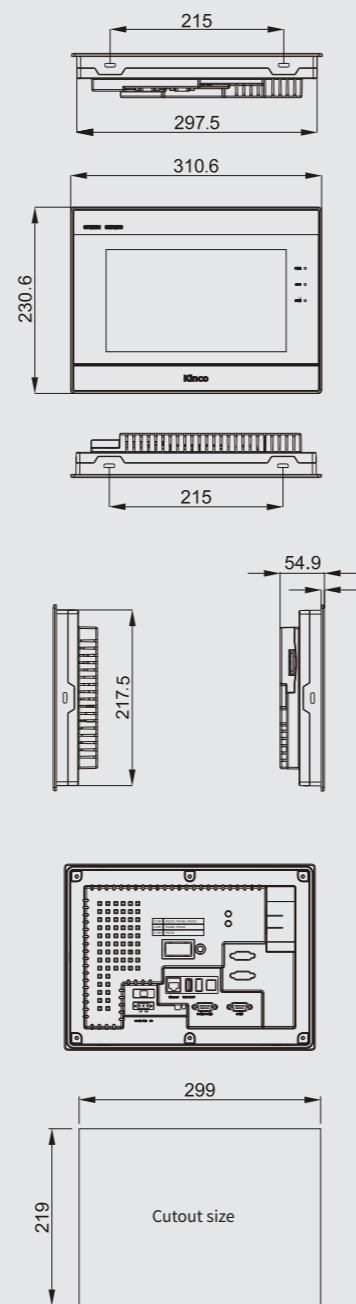

Note: G100-CAN is replacement of MT4512T and MT4522T; G100E is replacement of MT4512TE and MT4522TE.

# Standard Type

## G Series 12.1"

### G121E

- Advanced platform: NXP industrial-grade CPU, supply for more than 10 years
- Industrial display: 12.1", 4:3, provide bigger display area, highlights, and clarity
- Rich storage: Support external SD card and U disk, expandable up to 256GB
- Perfect protection: Built-in serial port isolation and isolated power supply to enhance reliability



Model/Specification	G121E
<b>Performance specifications</b>	
Display size	12.1" TFT
Display area	246(W)x184.5(H)
Resolution	800*600 pixels
Display color	65,536 color
Display angle of view	80/80/65/75 (left/right/up/down)
Contrast ratio	800:1
Backlight	LED
Brightness	400cd/m <sup>2</sup>
Backlight life	50,000 hours
Touch panel	4-wire precision resistance network (surface hardness: 4H)
Processor	ARM RISC 32Bit 800MHz
Storage	256 MB NAND Flash Memory + 128 MB DDR.3 Memory
RTC	Built-in
Expandable storage	1 USB Host+1 SD Card
Print port	USB host/serial port
Ethernet	LAN0:10/100Mbps
Program download	USB Slave (Micro USB)/U disk/Ethernet port
Communication port	COM0:RS232/RS485/RS422 COM1:RS485/RS422 COM2:RS232
<b>Electrical specifications</b>	
Input power supply	DC12V~DC28V, built-in isolated
Power consumption	10.9W@DC24V
Allowable loss of power	<3ms
Insulation resistance	Over 50MΩ@500V DC
Hi-pot test	500 VAC 1 minute
<b>Structure specifications</b>	
PCB coating (Yes/No)	Yes
Shell material	Engineering plastic
Shape size	350X260X54mm
Cutout size	340X250mm
Weight	2.2kg
<b>Environmental specifications</b>	
Operating ambient temperature	-10~55°C
Operating ambient humidity	10~90% RH (noncondensing)
Storage ambient temperature	-20~60°C
Storage ambient humidity	10~90% RH (noncondensing)
Sine vibration test	10~500Hz, 30m/S <sup>2</sup> , X, Y, Z directions/hour
Cooling mode	Natural air cooling
<b>Product certification</b>	
Panel protection grade	IP65 compliant (4208-93)
CE authentication	CE compliant (EN61000-6-4:2007+A1:2011, EN61000-6-2:2005)
<b>Software</b>	
Configuration software	Kinco DTools V4.1 and above

Mechanical Dimensions (Unit: mm)

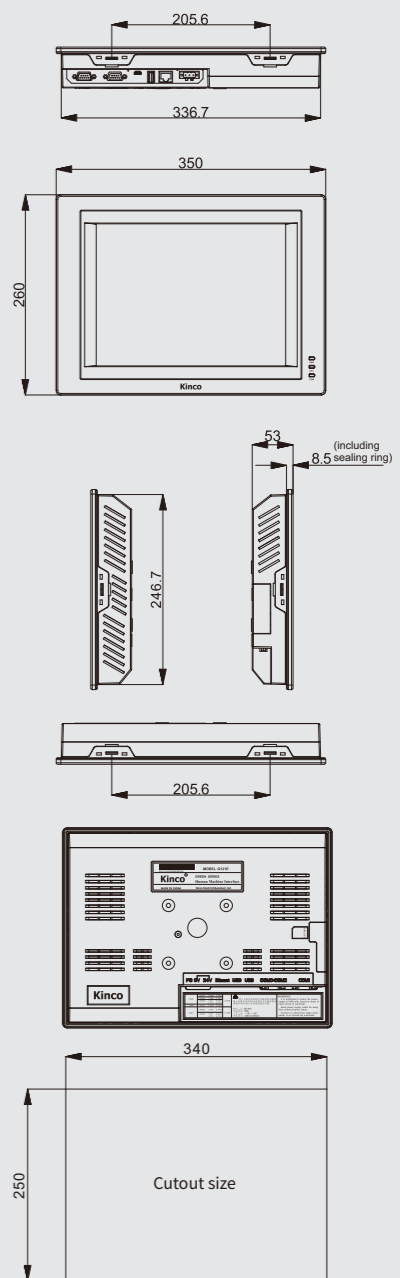

Note: G121E is replacement of MT4620TE and MT5620T.

# Standard Type

G Series **12.1"**

## G121HE

- 12.1" HD display, 16.77M true color
- With powerful script function, support edge computing
- With built-in IoT function, support teleservice
- Kinco DTools, a new generation of Kinco configuration software, with powerful function, simple and easy



Model/Specification	G121HE
<b>Performance specifications</b>	
Display size	12.1" TFT
Display area	246(W)x184.5(H)
Resolution	1,024*768 pixels
Display color	16.77M true color
Display angle of view	85/85/85/85 (left/right/up/down)
Contrast ratio	900:1
Backlight	LED
Brightness	400cd/m <sup>2</sup>
Backlight life	More than 30,000 hours
Touch panel	4-wire precision resistance network (surface hardness: 4H)
Processor	ARM RISC 32Bit 800MHz
Storage	256 MB NAND Flash Memory +256 MB DDR.3 Memory
RTC	Built-in
Expandable storage	1 USB Host+1 SD Card
Print port	USB host/serial port
Ethernet	LAN0:10/100Mbps
Program download	USB Slave (Micro USB)/U disk/Ethernet port
Communication port	COM0:RS232/RS485/RS422 COM1:RS485/RS422 COM2:RS232
<b>Electrical specifications</b>	
Input power supply	DC12V~DC28V, built-in isolated
Power consumption	10.8W@DC24V
Allowable loss of power	<3ms
Insulation resistance	Over 50MΩ@500V DC
Hi-pot test	500 VAC 1 minute
<b>Structure specifications</b>	
PCB coating (Yes/No)	Yes
Shell material	Engineering plastic
Shape size	350X260X54mm
Cutout size	339×249mm
Weight	2.2kg
<b>Environmental specifications</b>	
Operating ambient temperature	-10~55°C
Operating ambient humidity	10~90% RH (noncondensing)
Storage ambient temperature	-20~60°C
Storage ambient humidity	10~90% RH (noncondensing)
Sine vibration test	10~500Hz, 30m/S <sup>2</sup> , X, Y, Z directions/hour
Cooling mode	Natural air cooling
<b>Product certification</b>	
Panel protection grade	IP65 compliant (4208-93)
CE authentication	CE compliant (EN61000-6-4:2007+A1:2011, EN61000-6-2:2005)
<b>Software</b>	
Configuration software	Kinco DTools V3.5.3 and above

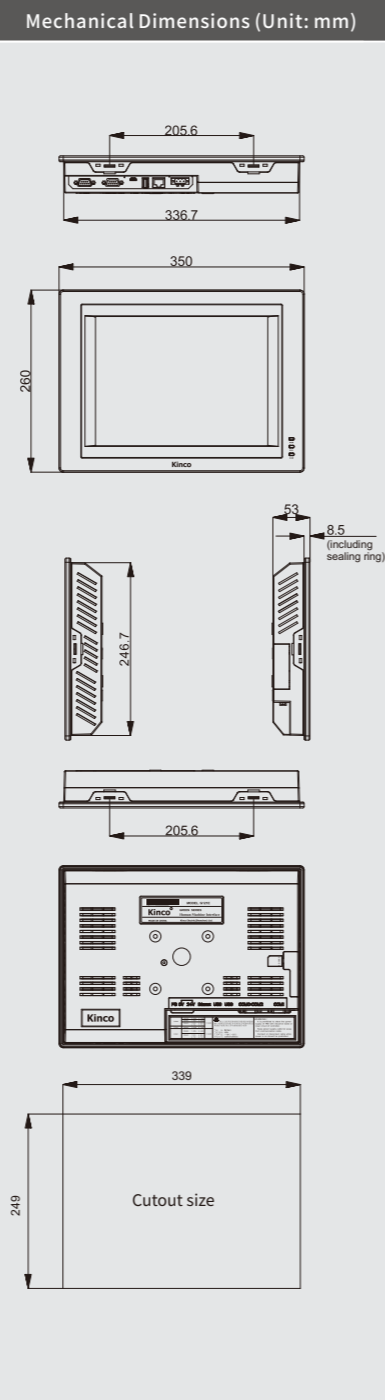

# Economy Type

GL Series **4.3"**

## GL043/GL043E

- Suitable for small space occasions
- Beautiful appearance, ultra-thin body
- High cost-effective



Model/Specification	GL043	GL043E
<b>Performance specifications</b>		
Display size	4.3" TFT	
Display area	95.04(W)x53.86(H)	
Resolution	480*272 pixels	
Display color	16.77M true color	
Display angle of view	70/70/50/70 (left/right/up/down)	
Contrast ratio	500:1	
Backlight	LED	
Brightness	450cd/m <sup>2</sup>	
Backlight life	More than 30,000 hours	
Touch panel	4-wire precision resistance network (surface hardness: 4H)	
Processor	ARM RISC 32Bit 800MHz	
Storage	256 MB NAND Flash Memory + 128 MB DDR.3 Memory	
RTC	Built-in	
Expandable storage	None	
Print port	Serial port	
Ethernet	None	LAN0:10/100Mbps
Program download	USB Slave (Micro USB)	USB Slave (Micro USB)/Ethernet port
Communication port	COM0:RS232/RS485/RS422 COM2:RS232	
<b>Electrical specifications</b>		
Input power supply	DC10V~DC28V	
Power consumption	2W@DC24V	
Allowable loss of power	<3ms	
Insulation resistance	Over 50MΩ@500V DC	
Hi-pot test	500 VAC 1 minute	
<b>Structure specifications</b>		
PCB coating (Yes/No)	None	
Shell material	Engineering plastic	
Shape size	132×102×33mm	
Cutout size	119×93mm	
Weight	0.21kg	
<b>Environmental specifications</b>		
Operating ambient temperature	0~50°C	
Operating ambient humidity	10~90% RH (noncondensing)	
Storage ambient temperature	-20~60°C	
Storage ambient humidity	10~90% RH (noncondensing)	
Sine vibration test	10~500Hz, 30m/S <sup>2</sup> , X, Y, Z directions/hour	
Cooling mode	Natural air cooling	
<b>Product certification</b>		
Panel protection grade	IP65 compliant (4208-93)	
CE authentication	CE compliant (EN61000-6-4:2007+A1:2011, EN61000-6-2:2005)	
<b>Software</b>		
Configuration software	Kinco DTools V4.1 and above	

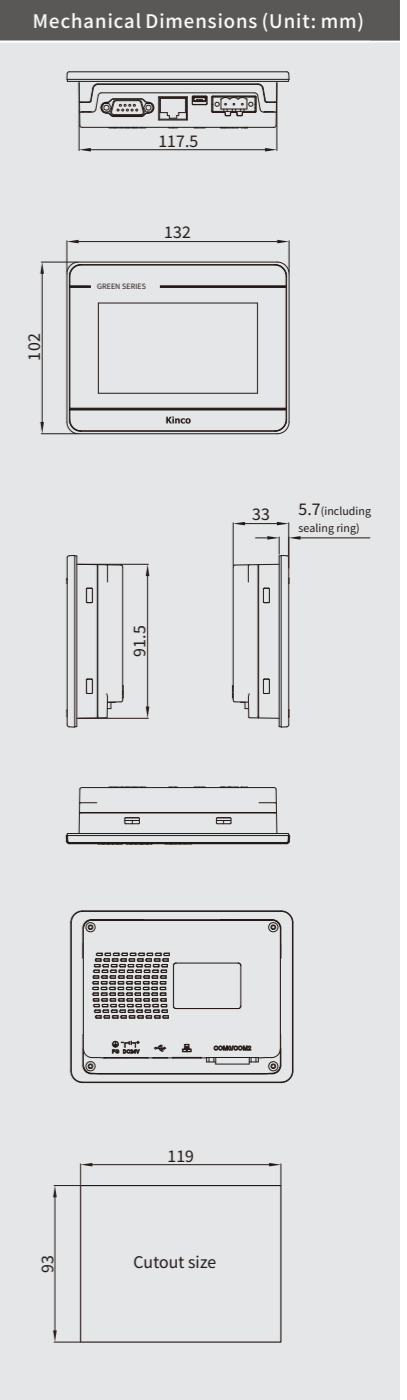

Note: GL043 is replacement of MT4230T; GL043E is replacement of MT4230TE.

# Economy Type

GL Series 7"

## GL070/GL070E

- Preferred model for general use
- A non-hollow mask is more effective against oil pollution
- Beautiful appearance, ultra-thin body
- Practical and more affordable



Model/Specification	GL070	GL070E
<b>Performance specifications</b>		
Display size	7" TFT	
Display area	154.08(W)x85.92(H)	
Resolution	1,024*600 pixels	
Display color	16.77M true color	
Display angle of view	85/85/85/85 (left/right/up/down)	
Contrast ratio	500:1	
Backlight	LED	
Brightness	450cd/m <sup>2</sup>	
Backlight life	More than 30,000 hours	
Touch panel	4-wire precision resistance network (surface hardness: 4H)	
Processor	ARM RISC 32Bit 800MHz	
Storage	256 MB NAND Flash Memory + 128 MB DDR.3 Memory	
RTC	Built-in	
Expandable storage	1 USB Host	
Print port	USB host/serial port	
Ethernet	None	LAN0:10/100Mbps
Program download	USB Slave (Micro USB)/U disk	USB Slave (Micro USB)/U disk/Ethernet port
Communication port	COM0:RS232/RS485/RS422 COM2:RS232	
<b>Electrical specifications</b>		
Input power supply	DC10V~DC28V	
Power consumption	3.6W@24VDC	
Allowable loss of power	<3ms	
Insulation resistance	Over 50MΩ@500V DC	
Hi-pot test	500 VAC 1 minute	
<b>Structure specifications</b>		
PCB coating (Yes/No)	None	
Shell material	Engineering plastic	
Shape size	204 × 150 × 37mm	
Cutout size	192 × 138mm	
Weight	0.5kg	
<b>Environmental specifications</b>		
Operating ambient temperature	0~50°C	
Operating ambient humidity	10~90% RH (noncondensing)	
Storage ambient temperature	-20~60°C	
Storage ambient humidity	10~90% RH (noncondensing)	
Sine vibration test	10~500Hz, 30m/S <sup>2</sup> , X, Y, Z directions/hour	
Cooling mode	Natural air cooling	
<b>Product certification</b>		
Panel protection grade	IP65 compliant (4208-93)	
CE authentication	CE compliant (EN61000-6-4:2007+A1:2011, EN61000-6-2:2005)	
<b>Software</b>		
Configuration software	Kinco DTools V4.1 and above	

Mechanical Dimensions (Unit: mm)

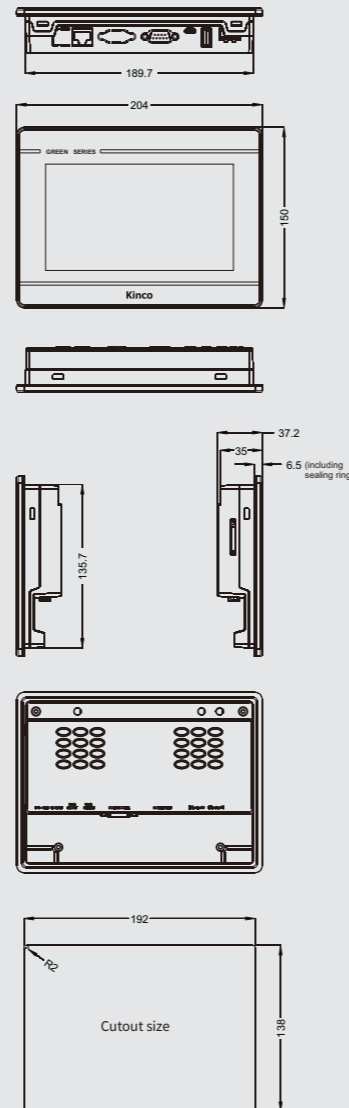

Note: GL070 is replacement of MT4434T; GL070E is replacement of MT4434TE-CAN.

# Economy Type

GL Series 10.1"

## GL100/GL100E

- Preferred models with approx. 10" screen for general use
- A non-hollow mask is more effective against oil pollution
- Beautiful appearance, ultra-thin body
- Practical and more affordable



Model/Specification	GL100	GL100E
<b>Performance specifications</b>		
Display size	10.1" TFT	
Display area	222.72(W)x125.28(H)	
Resolution	1,024*600 pixels	
Display color	16.77M true color	
Display angle of view	85/85/85/85 (left/right/up/down)	
Contrast ratio	500:1	
Backlight	LED	
Brightness	300cd/m <sup>2</sup>	
Backlight life	More than 30,000 hours	
Touch panel	4-wire precision resistance network (surface hardness: 4H)	
Processor	ARM RISC 32Bit 800MHz	
Storage	256 MB NAND Flash Memory + 128 MB DDR.3 Memory	
RTC	Built-in	
Expandable storage	1 USB Host	
Print port	USB host/serial port	
Ethernet	None	LAN0:10/100Mbps
Program download	USB Slave (Micro USB)/U disk	USB Slave (Micro USB)/U disk/Ethernet port
Communication port	COM0:RS232/RS485/RS422 COM2:RS232	
<b>Electrical specifications</b>		
Input power supply	DC10V~DC28V	
Power consumption	6W@24VDC	
Allowable loss of power	<3ms	
Insulation resistance	Over 50MΩ@500V DC	
Hi-pot test	500 VAC 1 minute	
<b>Structure specifications</b>		
PCB coating (Yes/No)	None	
Shell material	Engineering plastic	
Shape size	271 × 191 × 36mm	
Cutout size	260 × 179mm	
Weight	0.9kg	
<b>Environmental specifications</b>		
Operating ambient temperature	0~50°C	
Operating ambient humidity	10~90% RH (noncondensing)	
Storage ambient temperature	-20~60°C	
Storage ambient humidity	10~90% RH (noncondensing)	
Sine vibration test	10~500Hz, 30m/S <sup>2</sup> , X, Y, Z directions/hour	
Cooling mode	Natural air cooling	
<b>Product certification</b>		
Panel protection grade	IP65 compliant (4208-93)	
CE authentication	CE compliant (EN61000-6-4:2007+A1:2011, EN61000-6-2:2005)	
<b>Software</b>		
Configuration software	Kinco DTools V4.1 and above	

Mechanical Dimensions (Unit: mm)

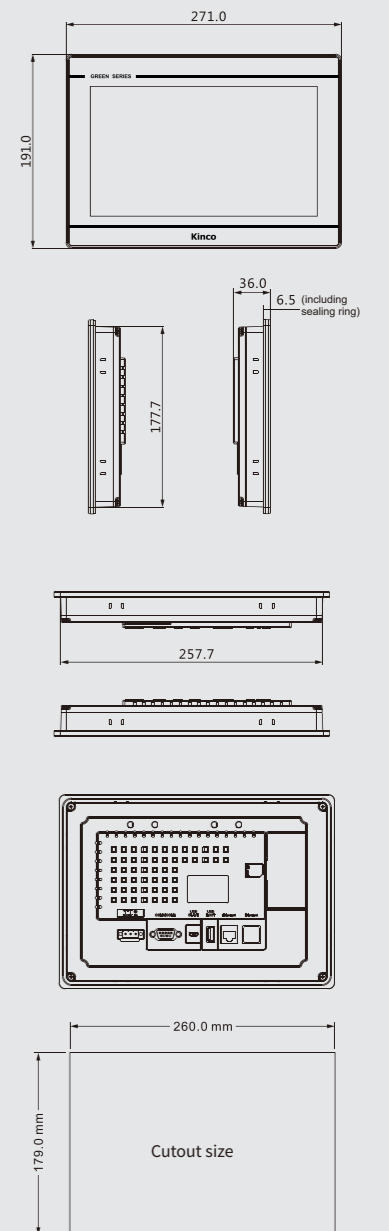

Note: GL100 is replacement of ET100 and MT4532T; GL100E is replacement of MT4532TE.

# Economy Type

GL Series 10.4"

## GL104E

- Built-in isolated power supply to enhance reliability
- Industrial size 4:3, possessing more visual coordination
- Firm and graceful structure
- Practical and more affordable



Model/Specification	GL104E
<b>Performance specifications</b>	
Display size	10.4" TFT
Display area	211.20(W)x158.40(H)
Resolution	800*600 pixels
Display color	16.77M true color
Display angle of view	70/70/60/70 (left/right/up/down)
Contrast ratio	500:1
Backlight	LED
Brightness	350cd/m <sup>2</sup>
Backlight life	More than 30,000 hours
Touch panel	4-wire precision resistance network (surface hardness: 4H)
Processor	ARM RISC 32Bit 800MHz
Storage	256 MB NAND Flash Memory + 128 MB DDR.3 Memory
RTC	Built-in
Expandable storage	1 USB Host
Print port	USB host/serial port
Ethernet	LAN0:10/100Mbps
Program download	USB Slave (Type B)/U disk/Ethernet port
Communication port	COM0:RS232/RS485/RS422 COM2:RS232
<b>Electrical specifications</b>	
Input power supply	DC10.8V~DC28V, built-in isolated
Power consumption	8W@DC24V
Allowable loss of power	<3ms
Insulation resistance	Over 50MΩ@500V DC
Hi-pot test	500 VAC 1 minute
<b>Structure specifications</b>	
PCB coating (Yes/No)	None
Shell material	Engineering plastic
Shape size	310×230×56mm
Cutout size	299×219mm
Weight	1.715kg
<b>Environmental specifications</b>	
Operating ambient temperature	0~50°C
Operating ambient humidity	10~90% RH (noncondensing)
Storage ambient temperature	-20~60°C
Storage ambient humidity	10~90% RH (noncondensing)
Sine vibration test	10~500Hz, 30m/S <sup>2</sup> , X, Y, Z directions/hour
Cooling mode	Natural air cooling
<b>Product certification</b>	
Panel protection grade	IP65 compliant (4208-93)
CE authentication	CE compliant (EN61000-6-4:2007+A1:2011, EN61000-6-2:2005)
<b>Software</b>	
Configuration software	Kinco DTools V3.5.3 and above

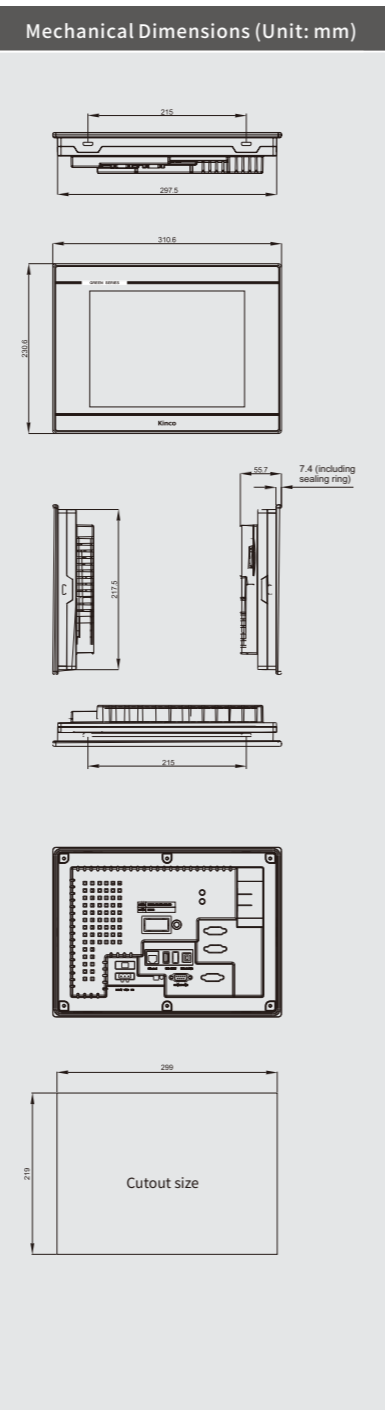

# Economy Type

GL Series 15"

## GL150E

- Preferred model with 15" screen
- Built-in isolated power supply to enhance reliability
- Industrial size 4:3, possessing more visual coordination
- Firm and graceful structure



Model/Specification	GL150E
<b>Performance specifications</b>	
Display size	15" TFT
Display area	304.13(W)x228.10(H)
Resolution	1,024*768 pixels
Display color	65,536 color
Display angle of view	80/80/80/80 (left/right/up/down)
Contrast ratio	800:1
Backlight	LED
Brightness	420cd/m <sup>2</sup>
Backlight life	50,000 hours
Touch panel	4-wire precision resistance network (surface hardness: 4H)
Processor	ARM RISC 32Bit 800MHz
Storage	256 MB NAND Flash Memory + 128 MB DDR.3 Memory
RTC	Built-in
Expandable storage	1 USB Host
Print port	USB host/serial port
Ethernet	LAN0:10/100Mbps
Program download	USB Slave (Micro USB)/U disk/Ethernet port
Communication port	COM0:RS232/RS485/RS422 COM2:RS232
<b>Electrical specifications</b>	
Input power supply	DC10.8V~DC28V, built-in isolated
Power consumption	1+W@24V DC
Allowable loss of power	<3ms
Insulation resistance	Over 50MΩ@500V DC
Hi-pot test	500 VAC 1 minute
<b>Structure specifications</b>	
PCB coating (Yes/No)	None
Shell material	Engineering plastic
Shape size	398×298×47mm
Cutout size	383×283mm
Weight	3kg
<b>Environmental specifications</b>	
Operating ambient temperature	-10~55°C
Operating ambient humidity	10~90% RH (noncondensing)
Storage ambient temperature	-20~60°C
Storage ambient humidity	10~90% RH (noncondensing)
Sine vibration test	10~500Hz, 30m/S <sup>2</sup> , X, Y, Z directions/hour
Cooling mode	Natural air cooling
<b>Product certification</b>	
Panel protection grade	IP65 compliant (4208-93)
CE authentication	CE compliant (EN61000-6-4:2007+A1:2011, EN61000-6-2:2005)
<b>Software</b>	
Configuration software	Kinco DTools V3.5.3 and above

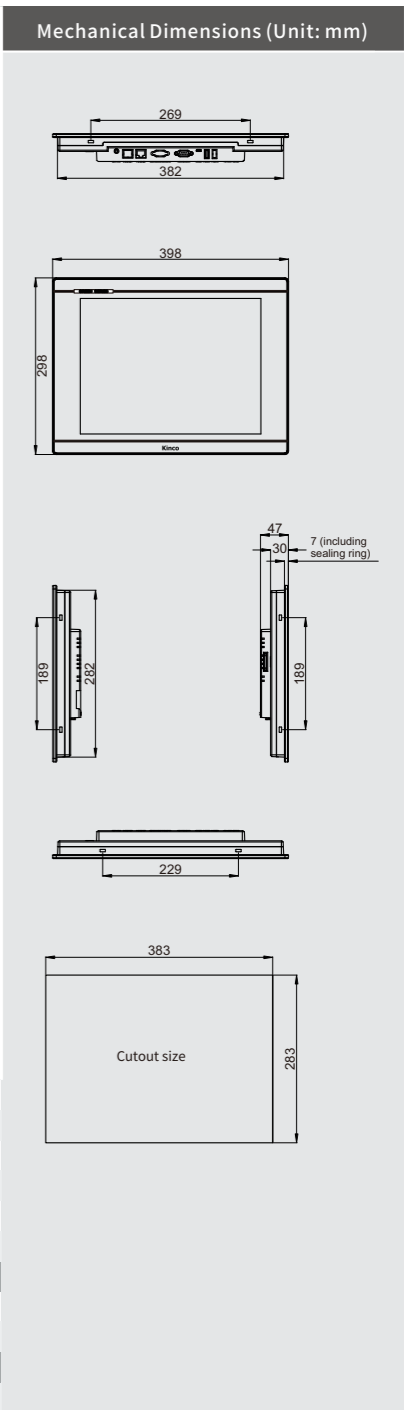

## GT Series 7"

### GT070HE / GT070HE-4G / GT070HE-WiFi

- 7" 1,024\*600 high resolution, high-brightness, full-view
- Support Ethernet and 4G/WiFi (external antenna required)
- With powerful script function, support edge computing
- With built-in IoT function, support teleservice
- Compatible with mainstream 10.1" configuration screen, easy to change screen



Model/Specification	GT070HE	GT070HE-4G	GT070HE-WiFi
<b>Performance specifications</b>			
Display size	7" TFT		
Display area	154.21(W)x85.92(H)		
Resolution	1,024*600 pixels		
Display color	16.77M true color		
Display angle of view	85/85/85/85 (left/right/up/down)		
Contrast ratio	800:1		
Backlight	LED		
Brightness	450cd/m <sup>2</sup>		
Backlight life	More than 30,000 hours		
Touch panel	4-wire precision resistance network (surface hardness: 4H)		
Processor	ARM RISC 32Bit 800MHz		
Storage	256 MB NAND Flash Memory + 128 MB DDR.3 Memory		
RTC	Built-in		
Expandable storage	1 USB Host		
Print port	USB host/serial port		
Ethernet	LAN0:10/100Mbps		
Network access	Ethernet	Ethernet, 4G wireless communication	Ethernet, Wi-Fi
Program download	USB Slave (Micro USB)/U disk/Ethernet port		
Wi-Fi/wireless network band	Not supported	LTE-FDD Band 1/3/5/8, LTE-TDD Band 38/39/40/41 UMTS Band 1/8, GSM Band 3/8	IEEE802.11b/g/n 802.11b:max 17dBm 802.11g:max 17dBm 802.11n:max 17dBm
Communication port	COM0:RS232/RS485/RS422; COM2:RS232		
<b>Electrical specifications</b>			
Input power supply	DC10.8V~DC28V		
Power consumption	4.2W@DC24V		
Allowable loss of power	<3ms		
Insulation resistance	超过50MΩ@500V DC		
Hi-pot tests	500 VAC 1 minute		
<b>Structure specifications</b>			
PCB coating (Yes/No)	None		
Shell material	Engineering plastic		
Shape size	204 × 150 × 37mm		
Cutout size	192 × 138 mm		
Weight	0.5kg		
<b>Environmental specifications</b>			
Operating ambient temperature	0~50°C		
Operating ambient humidity	10~90% RH (noncondensing)		
Storage ambient temperature	-20~60°C		
Storage ambient humidity	10~90% RH (noncondensing)		
Sine vibration test	10~500Hz, 30m/S <sup>2</sup> , X, Y, Z directions/hour		
Cooling mode	Natural air cooling		
<b>Product certification</b>			
Panel protection grade	IP65 compliant (4208-93)		
CE authentication	CE compliant (EN61000-6-4:2007+A1:2011, EN61000-6-2:2005)		
<b>Software</b>			
Configuration software	Kinco DTools V4.1 and above		

#### Mechanical Dimensions (Unit: mm)

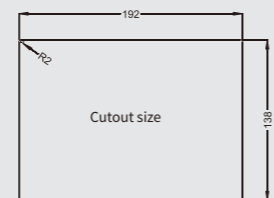
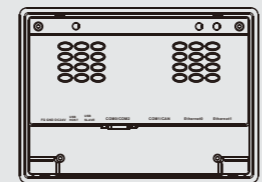
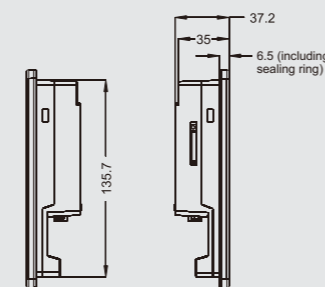
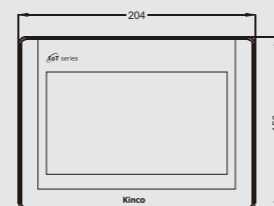

## GT Series 7"

### GT070E2

- 7", HD display, 16.77M true color
- Standard configuration: Dual Ethernet ports, being able to achieve data separation and ensure data security
- Designed with 3 serial ports, COM0 and COM1 support RS485 at the same time
- More storage space: 256MBFLASH Flash Memory + 256MBDDR3 Memory
- Three-proofing coating of mainboard, resistant to strong corrosion in severe environments



Model/Specification	GT070E2
<b>Performance specifications</b>	
Display size	7" TFT
Display area	154.21(W)x85.92(H)
Resolution	1,024*600 pixels
Display color	16.77M true color
Display angle of view	85/85/85/85 (left/right/up/down)
Contrast ratio	800:1
Backlight	LED
Brightness	450cd/m <sup>2</sup>
Backlight life	More than 30,000 hours
Touch panel	4-wire precision resistance network (surface hardness: 4H)
Processor	ARM RISC 32Bit 800MHz
Storage	256 MB NAND Flash Memory + 256 MB DDR.3 Memory
RTC	Built-in
Expandable storage	1 USB Host
Print port	USB host/serial port
Ethernet	LAN0:10/100MbpsLAN1:10/100Mbps
Network access	Ethernet
Program download	USB Slave (Micro USB)/U disk/Ethernet port
Communication port	COM0:RS232/RS485/RS422 COM1(RS485/RS422) COM2:RS232
<b>Electrical specifications</b>	
Input power supply	DC10.8V~DC28V
Power consumption	4.2W@DC24V
Allowable loss of power	<3ms
Insulation resistance	超过50MΩ@500V DC
Hi-pot tests	500 VAC 1 minute
<b>Structure specifications</b>	
PCB coating (Yes/No)	Yes
Shell material	Engineering plastic
Shape size	204 × 150 × 37mm
Cutout size	192 × 138 mm
Weight	0.6kg
<b>Environmental specifications</b>	
Operating ambient temperature	-10~50°C
Operating ambient humidity	10~90% RH (noncondensing)
Storage ambient temperature	-20~60°C
Storage ambient humidity	10~90% RH (noncondensing)
Sine vibration test	10~500Hz, 30m/S <sup>2</sup> , X, Y, Z directions/hour
Cooling mode	Natural air cooling
<b>Product certification</b>	
Panel protection grade	IP65 compliant (4208-93)
CE authentication	CE compliant (EN61000-6-4:2007+A1:2011, EN61000-6-2:2005)
<b>Software</b>	
Configuration software	Kinco DTools V3.5.3 and above

#### Mechanical Dimensions (Unit: mm)

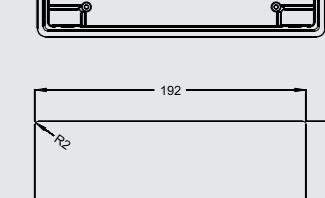
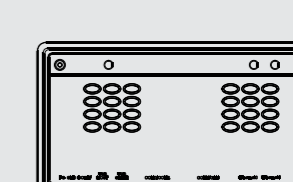
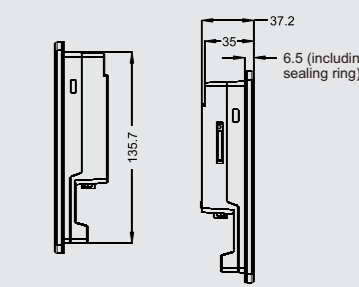
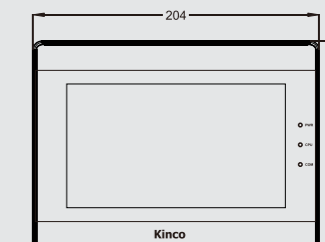
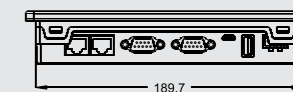

## GT Series 10.1"

### GT100E / GT100E-4G / GT100E-WiFi

- 10.1" HD display, 16.77M true color
- Support Ethernet and 4G/WiFi (external antenna required)
- With built-in IoT function, support teleservice
- Remote transmission, PLC program upload/download/online debugging/desktop monitoring



Model/Specification	GT100E	GT100E-4G	GT100E-WiFi
<b>Performance specifications</b>			
Display size	10.1" TFT		
Display area	222.72(W)x125.28(H)		
Resolution	1,024*600 pixels		
Display color	16.77M true color		
Display angle of view	85/85/85/85 (left/right/up/down)		
Contrast ratio	800:1		
Backlight	LED		
Brightness	350cd/m <sup>2</sup>		
Backlight life	More than 30,000 hours		
Touch panel	4-wire precision resistance network (surface hardness: 4H)		
Processor	ARM RISC 32Bit 800MHz		
Storage	256 MB NAND Flash Memory + 128 MB DDR.3 Memory		
RTC	Built-in		
Expandable storage	1 USB Host		
Print port	USB host/serial port		
Ethernet	LAN0:10/100Mbps		
Network access	Ethernet	Ethernet, 4G wireless communication	Ethernet, Wi-Fi
Program download	USB Slave (Micro USB)/U disk/Ethernet port		
Wi-Fi/wireless network band	Not supported	LTE-FDD Band 1/3/5/8, LTE-TDD Band 38/39/40/41 UMTS Band 1/8, GSM Band 3/8	IEEE802.11b/g/n 802.11b:max 17dBm 802.11g:max 17dBm 802.11n:max 17dBm
Communication port	COM0:RS232/RS485/RS422; COM2:RS232		
<b>Electrical specifications</b>			
Input power supply	DC10.8V~DC28V		
Power consumption	7W@DC24V		
Allowable loss of power	<3ms		
Insulation resistance	超过50MΩ@500V DC		
Hi-pot tests	500 VAC 1 minute		
<b>Structure specifications</b>			
PCB coating (Yes/No)	None		
Shell material	Engineering plastic		
Shape size	271×213×38mm		
Cutout size	260×202mm		
Weight	1.1kg		
<b>Environmental specifications</b>			
Operating ambient temperature	0~50°C		
Operating ambient humidity	10~90% RH (noncondensing)		
Storage ambient temperature	-20~60°C		
Storage ambient humidity	10~90% RH (noncondensing)		
Sine vibration test	10~500Hz, 30m/S <sup>2</sup> , X, Y, Z directions/hour		
Cooling mode	Natural air cooling		
<b>Product certification</b>			
Panel protection grade	IP65 compliant (4208-93)		
CE authentication	CE compliant (EN61000-6-4:2007+A1:2011, EN61000-6-2:2005)		
<b>Software</b>			
Configuration software	Kinco DTools V4.1 and above		

#### Mechanical Dimensions (Unit: mm)

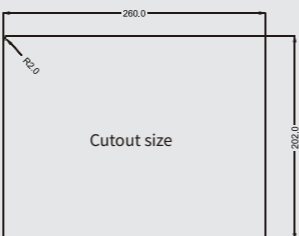
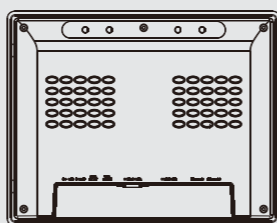
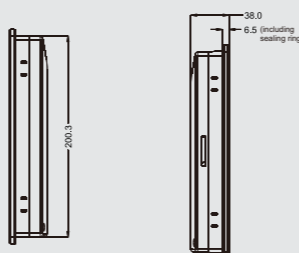
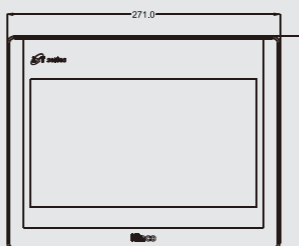

## GT Series 10.1"

### GT100E1

- 10.1" HD display, 16.77M true color
- Designed with 3 serial ports, COM0 and COM1 support RS485 at the same time
- Three-proofing coating of mainboard, resistant to strong corrosion in severe environments
- Built-in isolated power supply to prevent external interference and enhance reliability

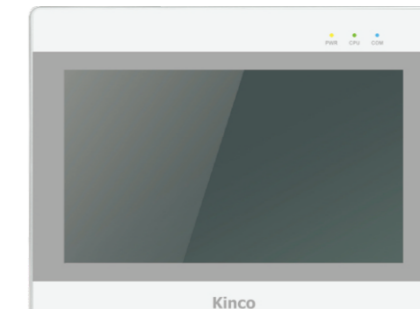

Model/Specification	GT100E1
<b>Performance specifications</b>	
Display size	10.1" TFT
Display area	227.72(W)x125.28(H)
Resolution	1,024*600 pixels
Display color	16.77M true color
Display angle of view	85/85/85/85 (left/right/up/down)
Contrast ratio	500:1
Backlight	LED
Brightness	350cd/m <sup>2</sup>
Backlight life	More than 30,000 hours
Touch panel	4-wire precision resistance network (surface hardness: 4H)
Processor	ARM RISC 32Bit 800MHz
Storage	256 MB NAND Flash Memory + 128 MB DDR.3 Memory
RTC	Built-in
Expandable storage	1 USB Host
Print port	USB host/serial port
Ethernet	LAN0:10/100Mbps
Network access	Ethernet
Program download	USB Slave (Micro USB)/U disk/Ethernet port
Communication port	COM0:RS232/RS485/RS422 COM1:RS485/RS422 COM2:RS232
<b>Electrical specifications</b>	
Input power supply	DC10.8V~DC28V, built-in isolated
Power consumption	5W@DC24V
Allowable loss of power	<3ms
Insulation resistance	超过50MΩ@500V DC
Hi-pot tests	500 VAC 1 minute
<b>Structure specifications</b>	
PCB coating (Yes/No)	Yes
Shell material	Engineering plastic
Shape size	271.1×213×38mm
Cutout size	260×202mm
Weight	1.1kg
<b>Environmental specifications</b>	
Operating ambient temperature	0~50°C
Operating ambient humidity	10~90% RH (noncondensing)
Storage ambient temperature	-20~60°C
Storage ambient humidity	10~90% RH (noncondensing)
Sine vibration test	10~500Hz, 30m/S <sup>2</sup> , X, Y, Z directions/hour
Cooling mode	Natural air cooling
<b>Product certification</b>	
Panel protection grade	IP65 compliant (4208-93)
CE authentication	CE compliant (EN61000-6-4:2007+A1:2011, EN61000-6-2:2005)
<b>Software</b>	
Configuration software	Kinco DTools V4.1 and above

#### Mechanical Dimensions (Unit: mm)

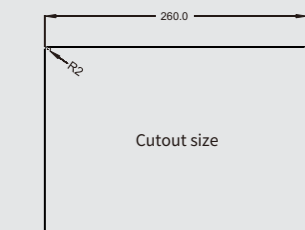
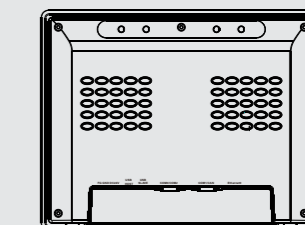
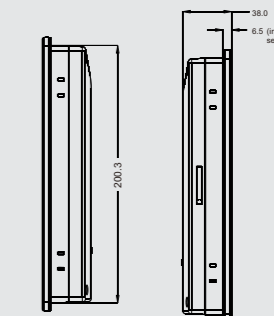
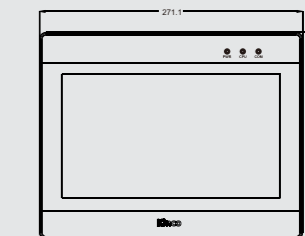

## GT Series 10.1"

### GT100E2/GT100E2-WiFi /GT100E2-4G/GT100E2-CAN

- 10.1" HD display, 16.77M true color;
- Standard configuration: Dual Ethernet ports, being able to achieve data separation and ensure data security;
- Support 4G/WiFi (built-in antenna);
- Three-proofing coating of mainboard, resistant to strong corrosion in severe environments;
- Built-in isolated power supply to prevent external interference and enhance reliability.



Model/Specification	GT100E2	GT100E2-WiFi	GT100E2-4G	GT100E2-CAN	Mechanical Dimensions (Unit: mm)
<b>Performance specifications</b>					
Display size	10.1" TFT				
Display area	222.72(W)x125.28(H)				
Resolution	1,024*600 pixels				
Display color	16.77M true color				
Display angle of view	70/70/60/60 (left/right/up/down)				
Contrast ratio	500:1				
Backlight	LED				
Brightness	350cd/m <sup>2</sup>				
Backlight life	More than 30,000 hours				
Touch panel	4-wire precision resistance network (surface hardness: 4H)				
Processor	ARM RISC 32Bit 800MHz				
Storage	256 MB NAND Flash Memory + 128 MB DDR.3 Memory				
RTC	Built-in				
Expandable storage	1 USB Host				
Print port	USB host/serial port				
Ethernet	USB Slave(Micro USB) / U disk/Ethernet port				
Network access	Ethernet	Ethernet, Wi-Fi	Ethernet, 4G wireless communication	Ethernet	
Bus port	None			1*CANopen	
Program download	USB Slave (Micro USB)/U disk/Ethernet port				
Wi-Fi/wireless network band	None	IEEE802.11b/g/n 802.11b: max 17dBm 802.11g: max 17dBm 802.11n: max 17dBm	LTE-FDD Band 1/3/5/8, LTE-TDD Band 38/39/40/41 TD-SCDMA Band 34/39, UMTS BCo, EVDO Bc0, CDMA1x BCo, GSM Band 3/5/8	None	
Communication port	COM0:RS232/RS485/RS422; COM1:RS485/RS422; COM2:RS232				
<b>Electrical specifications</b>					
Input power supply	DC10.8V~DC28V, built-in isolated				
Power consumption	5W@DC24V				
Allowable loss of power	<3ms				
Insulation resistance	Over 50MΩ@500V DC				
Hi-pot test	500 VAC 1 minute				
<b>Structure specifications</b>					
PCB coating (Yes/No)	Yes				
Shell material	Engineering plastic				
Shape size	271.1 × 213.0 × 38mm				
Cutout size	260 × 202mm				
Weight	1.1kg				
<b>Environmental specifications</b>					
Operating ambient temperature	-10~55°C				
Operating ambient humidity	10~90% RH (noncondensing)				
Storage ambient temperature	-20~60°C				
Storage ambient humidity	10~90% RH (noncondensing)				
Sine vibration test	10~500Hz, 30m/S <sup>2</sup> , X, Y, Z directions/hour				
Cooling mode	Natural air cooling				
<b>Product certification</b>					
Panel protection grade	IP65 compliant (4208-93)				
CE authentication	CE compliant (EN61000-6-4:2007+A1:2011, EN61000-6-2:2005)				
<b>Software</b>					
Configuration software	Kinco DTools V3.5.3 and above				

## GT Series 12.1"

### GT121E

- 12.1" HD display, 16.77M true color;
- With powerful script function, support edge computing
- With built-in IoT function, support teleservice.



Model/Specification	GT121E	Mechanical Dimensions (Unit: mm)
<b>Performance specifications</b>		
Display size	12.1" TFT	
Display area	246(W)x184.5(H)	
Resolution	1,024*768 pixels	
Display color	16.77M true color	
Display angle of view	85/85/85/85 (left/right/up/down)	
Contrast ratio	900:1	
Backlight	LED	
Brightness	400cd/m <sup>2</sup>	
Backlight life	30,000 hours	
Touch panel	4-wire precision resistance network (surface hardness: 4H)	
Processor	ARM RISC 32Bit 800MHz	
Storage	256 MB NAND Flash Memory + 128 MB DDR.3 Memory	
RTC	Built-in	
Expandable storage	1 USB Host +1 SD Card	
Print port	USB host/serial port	
Ethernet	LAN0:10/100Mbps	
Program download	USB Slave (Micro USB)/U disk/Ethernet port	
Communication port	COM0:RS232/RS485/RS422 COM1:RS485/RS422 COM2:RS232	
<b>Electrical specifications</b>		
Input power supply	DC12V~DC28V, built-in isolated	
Power consumption	10.8W@DC24V	
Allowable loss of power	<3ms	
Insulation resistance	Over 50MΩ@500V DC	
Hi-pot tests	500 VAC 1 minute	
<b>Structure specifications</b>		
PCB coating (Yes/No)	Yes	
Shell material	Engineering plastic	
Shape size	350 × 260 × 54mm	
Cutout size	339 × 249mm	
Weight	Approx. 2.2kg	
<b>Environmental specifications</b>		
Operating ambient temperature	-10~55°C	
Operating ambient humidity	10~90% RH (noncondensing)	
Storage ambient temperature	-20~60°C	
Storage ambient humidity	10~90% RH (noncondensing)	
Sine vibration test	10~500Hz, 30m/S <sup>2</sup> , X, Y, Z directions/hour	
Cooling mode	Natural air cooling	
<b>Product certification</b>		
Panel protection grade	IP65 compliant (4208-93)	
CE authentication	CE compliant (EN61000-6-4:2007+A1:2011, EN61000-6-2:2005)	
<b>Software</b>		
Configuration software	Kinco DTools V3.5.3 and above	

## GT Series 15"

### GT150E2

- 15" HD display
- Standard configuration: Dual Ethernet ports, being able to achieve data separation and ensure data security
- Three-proofing coating of mainboard, resistant to strong corrosion in severe environments
- Built-in isolated power supply to prevent external interference and enhance reliability



Model/Specification	GT150E2	Mechanical Dimensions (Unit: mm)
<b>Performance specifications</b>		
Display size	15" TFT	
Display area	304.13(W) x 228.10(H)	
Resolution	1,024*768 pixels	
Display color	65,536 color	
Display angle of view	80/80/80/80 (left/right/up/down)	
Contrast ratio	800:1	
Backlight	LED	
Brightness	420cd/m <sup>2</sup>	
Backlight life	50,000 hours	
Touch panel	4-wire precision resistance network (surface hardness: 4H)	
<b>Processor</b>		
Processor	ARM RISC 32Bit 800MHz	
<b>Storage</b>		
Storage	256 MB NAND Flash Memory + 128 MB DDR.3 Memory	
<b>RTC</b>		
RTC	Built-in	
<b>Expandable storage</b>		
Expandable storage	1 USB Host	
<b>Print port</b>		
Print port	USB host/serial port	
<b>Ethernet</b>		
Ethernet	LAN0:10/100Mbps	
<b>Program download</b>		
Program download	USB Slave (Micro USB)/U disk/Ethernet port	
<b>Communication port</b>		
Communication port	COM0:RS232/RS485/RS422; COM1:RS485/RS422; COM2:RS232	
<b>Electrical specifications</b>		
Input power supply	DC10.8V~DC28V, built-in isolated	
Power consumption	16W@DC24V	
Allowable loss of power	<3ms	
Insulation resistance	Over 50MΩ@500V DC	
Hi-pot test	500 VAC 1 minute	
<b>Structure specifications</b>		
PCB coating (Yes/No)	Yes	
Shell material	Engineering plastic	
Shape size	398 x 298 x 47mm	
Cutout size	383 x 283 mm	
Weight	3kg	
<b>Environmental specifications</b>		
Operating ambient temperature	-10~55°C	
Operating ambient humidity	10~90% RH (noncondensing)	
Storage ambient temperature	-20~60°C	
Storage ambient humidity	10~90% RH (noncondensing)	
Sine vibration test	10~500Hz, 30m/S <sup>2</sup> , X, Y, Z directions/hour	
Cooling mode	Natural air cooling	
<b>Product certification</b>		
Panel protection grade	IP65 compliant (4208-93)	
CE authentication	CE compliant (EN61000-6-4:2007+A1:2011, EN61000-6-2:2005)	
<b>Software</b>		
Configuration software	Kinco DTools V3.5.3 and above	

## GW Series IoT Gateways

### GW01 / GW01-4G / GW01-WiFi

- Freescale industrial-grade CPU, Main frequency: 800MHz, Memory: up to 128MB
- Designed with dual-port Ethernet ports and COM port for communication, able to connect hundreds of mainstream controllers, without need to change the existing architecture
- DTools, with simple configuration and powerful features, easy to achieve data mapping and transfer device data to the cloud
- Free choice of WiFi wireless communication or 4G module communication, adapting to different use scenarios
- Small size, easy to install (DIN rail mounting)



Model/Specification	GW01	GW01-4G	GW01-WiFi	Mechanical Dimensions (Unit: mm)
<b>Performance specifications</b>				
Processor	ARM RISC 32Bit 800MHz			
Storage	256 MB NAND Flash Memory + 128 MB DDR.3 Memory			
RTC	Built-in			
Ethernet	LAN0:10/100Mbps			
WiFi	None	None	2.4GHz WiFi	
4G	None	Built-in 4G module	None	
USB	1*USB Slave			
Program download	USB Slave (Micro USB)/ Ethernet port	USB Slave (Micro USB)/ Ethernet port	USB Slave (Micro USB)/ Ethernet port/WiFi	
Wi-Fi/ wireless network band	Not supported	LTE-FDD Band 1/3/5/8, LTE-TDD Band 38/39/40/41, UMTS Band 1/8, GSM Band 3/8	IEEE802.11b/g/n 802.11b:max 17dBm, 802.11g:max 17dBm, 802.11n:max 17dBm	
Communication port	COM0: RS232/RS422/RS485, COM2:RS232			
<b>Electrical specifications</b>				
Input power supply	DC12V~DC28V, built-in isolated			
Power consumption	1.5W@DC24V			
Allowable loss of power	<3ms			
Insulation resistance	Over 50MΩ@500V DC			
Hi-pot test	500 VAC 1 minute			
<b>Structure specifications</b>				
PCB coating (Yes/No)	None			
Shell color	Black			
Shell material	Metallic			
Shape size	111.6 x 93.6 x 30mm			
Cutout size	DIN rail mounting (35mm)			
Weight	0.31kg			
<b>Environmental specifications</b>				
Operating ambient temperature	-10~55°C			
Operating ambient humidity	10~90% RH (noncondensing)			
Storage ambient temperature	-20~60°C			
Storage ambient humidity	10~90% RH (noncondensing)			
Sine vibration test	10~500Hz, 30m/S <sup>2</sup> , X, Y, Z directions/hour			
Cooling mode	Natural air cooling			
<b>Product certification</b>				
Panel protection grade	IP20 compliant			
CE authentication	CE compliant (EN61000-6-4:2007+A1:2011, EN61000-6-2:2005)			
<b>Software</b>				
Configuration software	Kinco DTools V4.1 and above			

# FUTURE Series Industrial HMIs for High-end equipment industry

Kinco FUTURE series industrial HMIs balance the steady industrial-grade needs with the enjoyment of new technologies; By virtue of strict material selection and innovative design, the products can achieve an ultra-long life cycle of 10 years; Produced by Kinco Intelligent Manufacturing Center, their materials and whole manufacturing process can be traced to ensure high quality; Customers can enjoy the new features of DTools (configuration software); With the industry leading edge, we create high-end equipment preferred products.



## 7 leading advantages for high-end equipment industry

**1**

**Powerful core platform**  
Industrial-grade CPU, Main frequency: 1GHz

- 1GHz Based on Cortex-A9
- 512MB DDR3 large memory
- 4GB eMMC large storage space

**2**

**Support Ethernet video monitoring**

- Support webcams
- Leading the new trend of industrial equipment video-based scenario monitoring
- The full series products support the ONVIF standard

**3**

**High quality, more stable**

- Three-proofing coating of mainboard
- Built-in isolated power supply
- Pure PC material makes it strong
- Operating over a wide temperature range
- Produced by Kinco Intelligent Manufacturing Center: whole-process quality tracking and monitoring

**4**

**Recipe data, freely erasable**

- The unique built-in ferroelectric storage allows frequent erasure
- Important saved data will not be lost, and frequency will not be lower; fast data reading-writing is perfectly combined with power-off saving

**5**

**Original industrial LCD required for stability**

- Original LCD
- 16.77M true color
- Wide temperature range: -30°C~80°C

**6**

**Standard audio output**

- Make the equipment operating with color and sound

**7**

**Built-in IoT function**

Seamless docking with Kinco M-IoT

Data cleaning  
Edge calculation

Remote download

Remote monitoring

Seamless docking with Alibaba Cloud IIoT

Easy data to cloud

Remote upload

PLC remote on-line debugging

# FUTURE Series F070E

- Cortex-A9 industrial-grade CPU, Main frequency: 1GHz, Memory: up to 512M;
- 7", high brightness and high resolution display;
- With built-in ferroelectric storage, support unlimited erasure of recipe data;
- Three-proofing coating + isolated power supply to enhance reliability;
- Support access to webcams, and achieve real-time dynamic control;
- Kinco DTools, a new generation of Kinco configuration software, with powerful function, simple and easy.



Model/Specification	F070E
<b>Performance specifications</b>	
Display size	7" TFT
Resolution	800*480 pixels
Display color	16.77M true color
Backlight	LED
Brightness	400cd/m <sup>2</sup>
Backlight life	More than 30,000 hours
Touch panel	4-wire precision resistance network (surface hardness: 4H)
Processor	32Bit RISC Cortex-A9 1GHz
Storage	512MB DDR3+8GB eMMC
RTC & recipe storage	RTC + 32KB
Expandable storage	USB Host
Print port	USB/serial port
Ethernet	LAN0:10/100Mbps
Program download	USB Slave (Micro USB)/U disk/Ethernet port
Communication port	COM0:RS232/RS485/RS422 COM1:RS232/RS485/RS422 COM2:RS232
Audio output	1* audio output
Expandable interface	Not supported
<b>Electrical specifications</b>	
Input power supply	DC12V~DC28V, built-in isolated
Power consumption	5W@DC24V
Allowable loss of power	<3ms
Insulation resistance	Over 50MΩ@500V DC
Hi-pot test	500 VAC 1 minute
<b>Structure specifications</b>	
PCB coating (Yes/No)	Yes
Shell color	Gray
Shell material	Engineering plastic
Shape size	204×150×37.2 mm
Cutout size	192×138 mm
Weight	0.57kg
<b>Environmental specifications</b>	
Operating ambient temperature	-10~55°C
Operating ambient humidity	10~90% RH (noncondensing)
Storage ambient temperature	-20~60°C
Storage ambient humidity	10~90% RH (noncondensing)
Sine vibration test	10~500Hz, 30m/S <sup>2</sup> , X, Y, Z directions/hour
Cooling mode	Natural air cooling
<b>Product certification</b>	
Panel protection grade	IP65 compliant
CE authentication	CE compliant
<b>Software</b>	
Configuration software	Kinco DTools V3.5.3 and above

**Mechanical Dimensions (Unit: mm)**

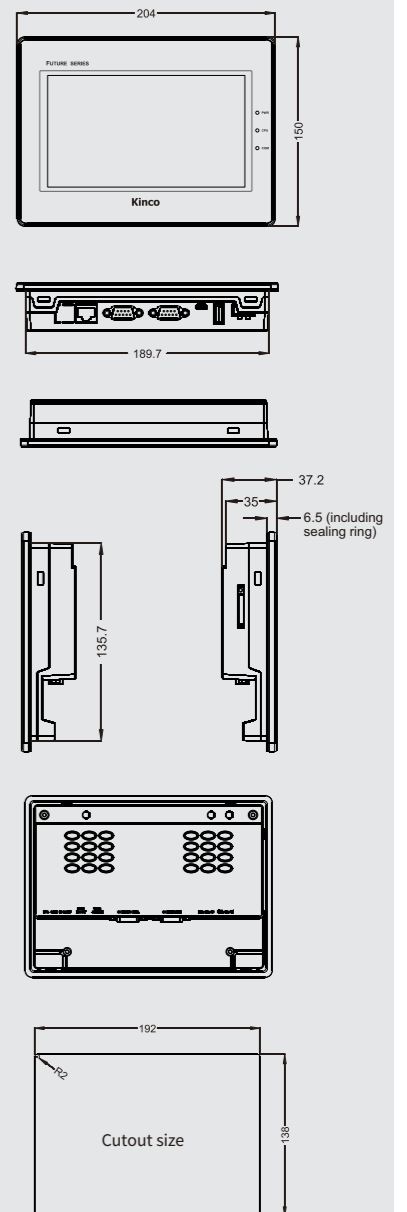

## FUTURE Series F080E

- Cortex-A9 industrial-grade CPU, Main frequency: 1GHz, Memory: up to 512M;
- 8", high brightness and high resolution display, industrial size 4:3;
- With built-in ferroelectric storage, support unlimited erasure of recipe data;
- Three-proofing coating + isolated power supply to enhance reliability;
- SD card expands the storage space;
- Support access to webcams, and achieve real-time dynamic control;
- Support MPI 187.5K.



Model/Specification	F080E
<b>Performance specifications</b>	
Display size	8" TFT
Resolution	800*600 pixels
Display color	16.77M true color
Backlight	LED
Brightness	250cd/m <sup>2</sup>
Backlight life	More than 30,000 hours
Touch panel	4-wire precision resistance network (surface hardness: 4H)
Processor	32Bit RISC Cortex-A9 1GHz
Storage	512MB DDR3+4GB eMMC
RTC & recipe storage	RTC + 32KB
Expandable storage	2 USB Host+ 1SD Card
Print port	USB/serial port
Ethernet	LAN0:10/100Mbps
Program download	U disk/Ethernet port
Communication port	COM0:RS232/RS485/RS422 COM1:RS232/RS485/RS422 COM2:RS232
Audio output	1* audio output
Expandable interface	Not supported
<b>Electrical specifications</b>	
Input power supply	DC12V~DC28V, built-in isolated
Power consumption	8W@DC24V
Allowable loss of power	<3ms
Insulation resistance	Over 50MΩ@500V DC
Hi-pot test	500 VAC 1 minute
<b>Structure specifications</b>	
PCB coating (Yes/No)	Yes
Shell color	Beige white
Shell material	Engineering plastic
Shape size	235×172×57.9mm
Cutout size	224×161mm
Weight	1.3kg
<b>Environmental specifications</b>	
Operating ambient temperature	-10~55°C
Operating ambient humidity	10~90% RH (noncondensing)
Storage ambient temperature	-20~60°C
Storage ambient humidity	10~90% RH (noncondensing)
Sine vibration test	10~500Hz, 30m/S <sup>2</sup> , X, Y, Z directions/hour
Cooling mode	Natural air cooling
<b>Product certification</b>	
Panel protection grade	IP65 compliant
CE authentication	CE compliant (EN61000-6-4:2007+A1:2011, EN61000-6-2:2005)
<b>Software</b>	
Configuration software	Kinco DTools V3.5.3 and above

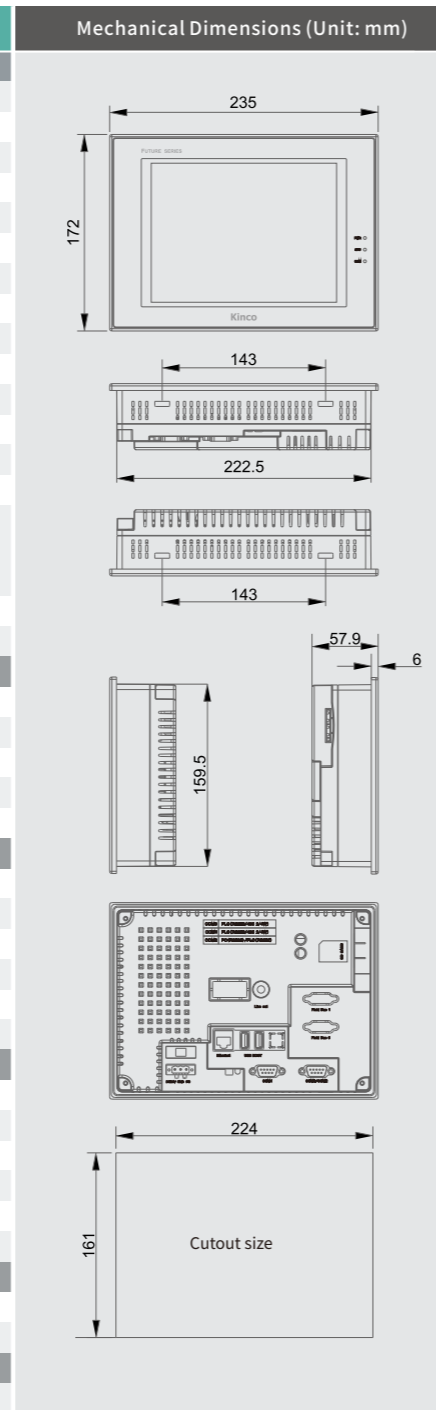

Note: F080E is replacement of MT4403T, MT4403TE and MT5423T.

## FUTURE Series F104E/F104E-CAN

- Cortex-A9 industrial-grade CPU, Main frequency: 1GHz, Memory: up to 512M;
- 10.4", high brightness and high resolution display, industrial size 4:3;
- With built-in ferroelectric storage, support unlimited erasure of recipe data;
- Three-proofing coating + isolated power supply to enhance reliability;
- SD card expands the storage space;
- Support access to webcams, and achieve real-time dynamic control;
- Support MPI 187.5K.



Model/Specification	F104E	F104E-CAN
<b>Performance specifications</b>		
Display size	10.4" TFT	
Resolution	1,024*768 pixels	
Display color	16.77M true color	
Backlight	LED	
Brightness	450cd/m <sup>2</sup>	
Backlight life	More than 50,000 hours	
Touch panel	4-wire precision resistance network (surface hardness: 4H)	
Processor	32Bit RISC Cortex-A9 1GHz	
Storage	512MB DDR3+4GB eMMC	
RTC & recipe storage	RTC + 32KB	
Expandable storage	2 USB Host + 1SD Card	
Print port	USB/serial port	
Ethernet	LAN0:10/100Mbps	
Program download	U disk/Ethernet port	
Communication port	COM0:RS232/RS485/RS422 COM1:RS232/RS485/RS422 COM2:RS232	COM0:RS232/RS485/RS422 COM1:RS232/RS485/RS422 COM2:RS232
Audio output	1* audio output	1* audio output
Expandable interface	Not supported	1* CANopen
<b>Electrical specifications</b>		
Input power supply	DC12V~DC28V, built-in isolated	DC12V~DC28V, built-in isolated
Power consumption	12W@DC24V	12W@DC24V
Allowable loss of power	<3ms	<3ms
Insulation resistance	Over 50MΩ@500V DC	Over 50MΩ@500V DC
Hi-pot test	500 VAC 1 minute	500 VAC 1 minute
<b>Structure specifications</b>		
PCB coating (Yes/No)	Yes	Yes
Shell color	Beige white	Beige white
Shell material	Engineering plastic	Engineering plastic
Shape size	310.6×230.6×55.7 mm	310.6×230.6×55.7 mm
Cutout size	299×219 mm	299×219 mm
Weight	1.7kg	1.7kg
<b>Environmental specifications</b>		
Operating ambient temperature	-10~55°C	-10~55°C
Operating ambient humidity	10~90% RH (noncondensing)	10~90% RH (noncondensing)
Storage ambient temperature	-20~60°C	-20~60°C
Storage ambient humidity	10~90% RH (noncondensing)	10~90% RH (noncondensing)
Sine vibration test	10~500Hz, 30m/S <sup>2</sup> , X, Y, Z directions/hour	10~500Hz, 30m/S <sup>2</sup> , X, Y, Z directions/hour
Cooling mode	Natural air cooling	Natural air cooling
<b>Product certification</b>		
Panel protection grade	IP65 compliant	IP65 compliant
CE authentication	CE compliant (EN61000-6-4:2007+A1:2011, EN61000-6-2:2005)	CE compliant (EN61000-6-4:2007+A1:2011, EN61000-6-2:2005)
<b>Software</b>		
Configuration software	Kinco DTools V3.5.3 and above	Kinco DTools V3.5.3 and above

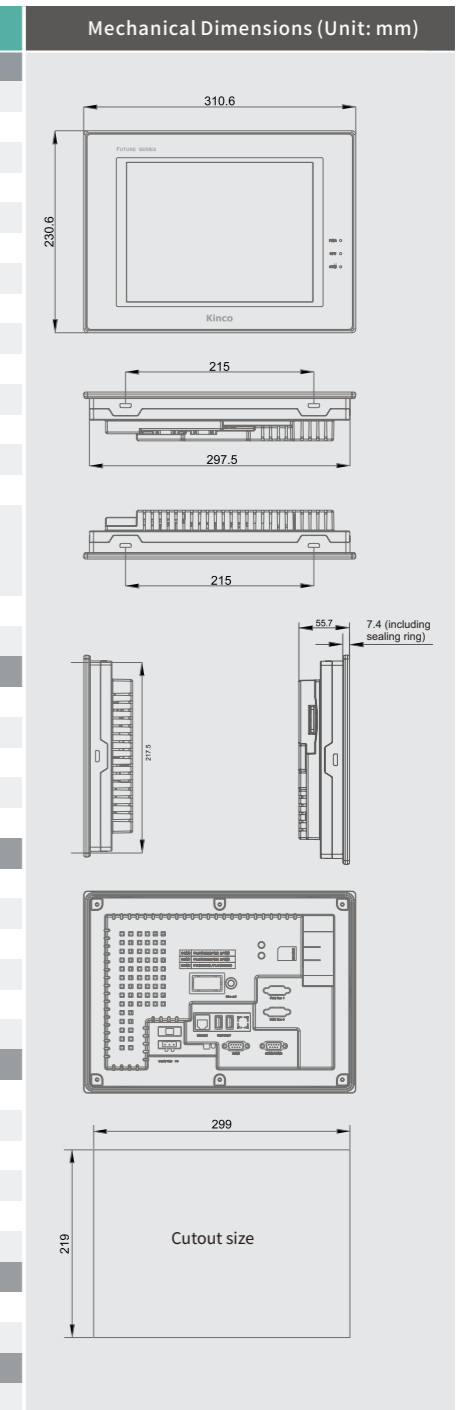

Note: F104E is replacement of MT5520T and MT5520T-MPI; F104E-CAN is replacement of MT5520T-CAN.

## FUTURE Series F121E

- Industrial-grade CPU, Main frequency: 1GHz;
- 12.1" HD LCD, 16.77M true color, full-view display;
- 8GB eMMC huge memory +512MB DDR3 memory, Expandable storage: 1\*SD+2\*USB host;
- 3 serial ports, all with serial port isolation;
- Built-in isolated power supply and PCB protection;
- Support access to webcams, and achieve real-time dynamic control;
- Support OPC UA, MQTT and other IoT protocols, Siemens tag protocol, etc.



Model/Specification	F121E
<b>Performance specifications</b>	
Display size	12.1" TFT
Resolution	1,024*768 pixels
Display color	16.77M true color
Backlight	LED
Display angle of view	88/88/88/88 (left/right/up/down)
Brightness	500cd/m <sup>2</sup>
Backlight life	More than 50,000 hours
Touch panel	4-wire precision resistance network (surface hardness: 4H)
Processor	32Bit RISC Cortex-A9 1GHz
Storage	512MB DDR3+4GB eMMC
RTC & recipe storage	RTC + 32KB
Expandable storage	2 USB Host+ 1SD Card
Print port	USB host/serial port
Ethernet	LAN0:10/100Mbps
Program download	U disk/Ethernet port
Communication port	COM0:RS232/RS485/RS422 COM1:RS232/RS485/RS422 COM2:RS232
Audio output	1* audio output
Expandable interface	1*CANopen
<b>Electrical specifications</b>	
Input power supply	DC12V~DC28V, built-in isolated
Power consumption	18W@DC24V
Allowable loss of power	<3ms
Insulation resistance	Over 50MΩ@500V DC
Hi-pot test	500 VAC 1 minute
<b>Structure specifications</b>	
PCB coating (Yes/No)	Yes
Shell color	Black
Shell material	Engineering plastic
Shape size	350×264×48.9mm
Cutout size	328×242mm
Weight	3.6kg
<b>Environmental specifications</b>	
Operating ambient temperature	-10~55°C
Operating ambient humidity	10~90% RH (noncondensing)
Storage ambient temperature	-20~60°C
Storage ambient humidity	10~90% RH (noncondensing)
Sine vibration test	10~500Hz, 30m/S <sup>2</sup> , X, Y, Z directions/hour
Cooling mode	Natural air cooling
<b>Product certification</b>	
Panel protection grade	IP65 compliant
CE authentication	CE compliant
<b>Software</b>	
Configuration software	Kinco DTools V3.5.3 and above

Mechanical Dimensions (Unit: mm)

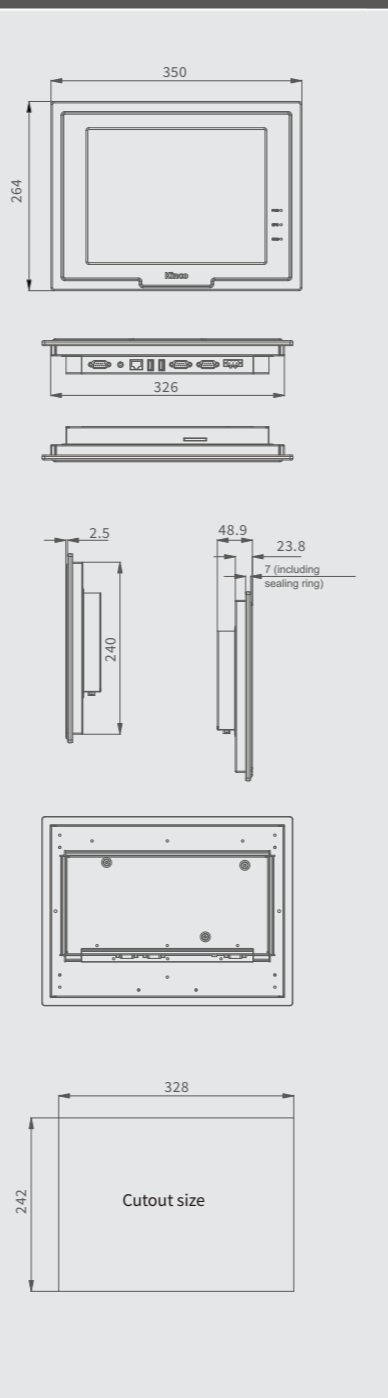

## FUTURE Series F121EW

- Industrial-grade CPU, Main frequency: 1GHz;
- 12.1" HD LCD, 16.77M true color, full-view display;
- 8GB eMMC huge memory +512MB DDR3 memory, Expandable storage: 1\*SD+2\*USB host;
- 3 serial ports, all with serial port isolation;
- Built-in isolated power supply and PCB protection;
- Support access to webcams, and achieve real-time dynamic control;
- Support OPC UA, MQTT and other IoT protocols, Siemens tag protocol, etc.



Model/Specification	F121EW
<b>Performance specifications</b>	
Display size	12.1" TFT
Resolution	1,024*768 pixels
Display color	16.77M true color
Backlight	LED
Display angle of view	88/88/88/88 (left/right/up/down)
Brightness	500cd/m <sup>2</sup>
Backlight life	More than 50,000 hours
Touch panel	4-wire precision resistance network (surface hardness: 4H)
Processor	32Bit RISC Cortex-A9 1GHz
Storage	512MB DDR3+8GB eMMC
RTC & recipe storage	RTC + 32KB
Expandable storage	2 USB Host+ 1SD Card
Print port	USB host/serial port
Ethernet	LAN0:10/100Mbps
Program download	U disk/Ethernet port
Communication port	COM0:RS232/RS485/RS422 COM1:RS232/RS485/RS422 COM2:RS232
Audio output	1* audio output
Expandable interface	1*CANopen
<b>Electrical specifications</b>	
Input power supply	DC12V~DC28V, built-in isolated
Power consumption	18W@DC24V
Allowable loss of power	<3ms
Insulation resistance	Over 50MΩ@500V DC
Hi-pot test	500 VAC 1 minute
<b>Structure specifications</b>	
PCB coating (Yes/No)	Yes
Shell color	Beige white
Shell material	Metallic
Shape size	313x235x47.5mm
Cutout size	295x217mm
Weight	3.6kg
<b>Environmental specifications</b>	
Operating ambient temperature	-10~55°C
Operating ambient humidity	10~90% RH (noncondensing)
Storage ambient temperature	-20~60°C
Storage ambient humidity	10~90% RH (noncondensing)
Sine vibration test	10~500Hz, 30m/S <sup>2</sup> , X, Y, Z directions/hour
Cooling mode	Natural air cooling
<b>Product certification</b>	
Panel protection grade	IP65 compliant
CE authentication	CE compliant (EN6100-6-4:2007+A1:2011, EN61000-6-2:2005)
<b>Software</b>	
Configuration software	Kinco DTools V3.5.3 and above

Mechanical Dimensions (Unit: mm)

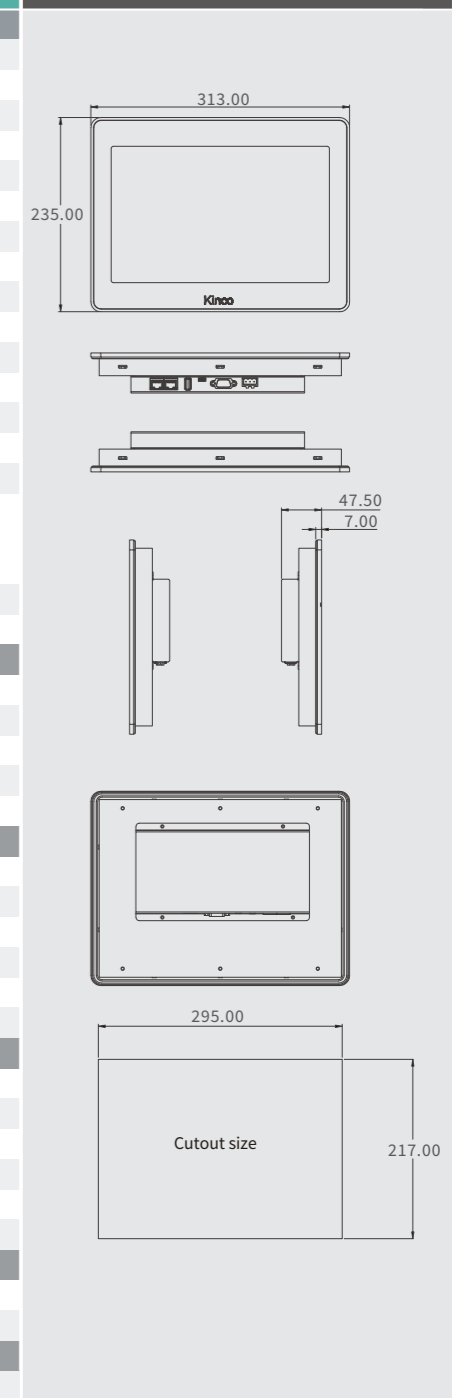

## FUTURE Series F150E

- Cortex-A9 industrial-grade CPU, Main frequency: 1GHz, Memory: up to 512M;
- 15", high brightness and high resolution display, industrial size 4:3;
- With built-in ferroelectric storage, support unlimited erasure of recipe data;
- SD card expands the storage space;
- Support access to webcams, and achieve real-time dynamic control;
- Support MPI 187.5K.



Model/Specification	F150E
<b>Performance specifications</b>	
Display size	15" TFT
Resolution	1,024*768 pixels
Display color	16.77M true color
Backlight	LED
Brightness	300cd/m <sup>2</sup>
Backlight life	More than 50,000 hours
Touch panel	4-wire precision resistance network (surface hardness: 4H)
Processor	32Bit RISC Cortex-A9 1GHz
Storage	512MB DDR3+4GB eMMC
RTC & recipe storage	RTC + 32KB
Expandable storage	2 USB Host+ 1SD Card
Print port	USB host/serial port
Ethernet	LAN0:10/100Mbps
Program download	U disk/Ethernet port
Communication port	COM0:RS232/RS485/RS422 COM1:RS232/RS485/RS422 COM2:RS232
Audio output	1* audio output
Expandable interface	1* CANopen
<b>Electrical specifications</b>	
Input power supply	DC12V~DC28V, built-in isolated
Power consumption	12W@DC24V
Allowable loss of power	<3ms
Insulation resistance	Over 50MΩ@500V DC
Hi-pot test	500 VAC 1 minute
<b>Structure specifications</b>	
PCB coating (Yes/No)	Yes
Shell color	Black
Shell material	Metallic
Shape size	406.5×313.5×48.3mm
Cutout size	387.5×294.5mm
Weight	5kg
<b>Environmental specifications</b>	
Operating ambient temperature	-10~55°C
Operating ambient humidity	10~90% RH (noncondensing)
Storage ambient temperature	-20~60°C
Storage ambient humidity	10~90% RH (noncondensing)
Sine vibration test	10~500Hz, 30m/S <sup>2</sup> , X, Y, Z directions/hour
Cooling mode	Natural air cooling
<b>Product certification</b>	
Panel protection grade	IP65 compliant
CE authentication	CE compliant (EN6100-6-4:2007+A1:2011, EN61000-6-2:2005)
Software	
Configuration software	Kinco DTools V3.5.3 and above

Mechanical Dimensions (Unit: mm)

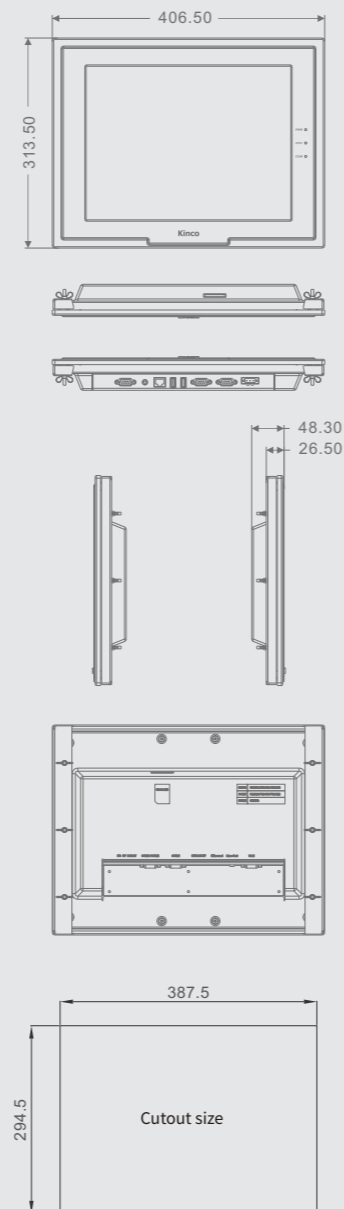

## FUTURE Series F150EW

- Cortex-A9 industrial-grade CPU, Main frequency: 1GHz, Memory: up to 512M;
- 15", high brightness and high resolution display, industrial size 4:3;
- With built-in ferroelectric storage, support unlimited erasure of recipe data;
- SD card expands the storage space;
- Support access to webcams, and achieve real-time dynamic control;
- Support MPI 187.5K.



Model/Specification	F150EW
<b>Performance specifications</b>	
Display size	15" TFT
Resolution	1,024*768 pixels
Display color	16.77M true color
Backlight	LED
Brightness	300cd/m <sup>2</sup>
Backlight life	More than 50,000 hours
Touch panel	4-wire precision resistance network (surface hardness: 4H)
Processor	32Bit RISC Cortex-A9 1GHz
Storage	512MB DDR3+4GB eMMC
RTC & recipe storage	RTC + 32KB
Expandable storage	2 USB Host + 1SD Card
Print port	USB host/serial port
Ethernet	LAN0:10/100Mbps
Program download	U disk/Ethernet port
Communication port	COM0:RS232/RS485/RS422; COM1:RS232/RS485/RS422 COM2:RS232
Audio output	1* audio output
Expandable interface	1* CANopen
<b>Electrical specifications</b>	
Input power supply	DC12V~DC28V, built-in isolated
Power consumption	12W@DC24V
Allowable loss of power	<3ms
Insulation resistance	Over 50MΩ@500V DC
Hi-pot test	500 VAC 1 minute
<b>Structure specifications</b>	
PCB coating (Yes/No)	Yes
Shell color	Beige white
Shell material	Engineering plastic
Shape size	366x293x49.5mm
Cutout size	352x279mm
Weight	5kg
<b>Environmental specifications</b>	
Operating ambient temperature	-10~55°C
Operating ambient humidity	10~90% RH (noncondensing)
Storage ambient temperature	-20~60°C
Storage ambient humidity	10~90% RH (noncondensing)
Sine vibration test	10~500Hz, 30m/S <sup>2</sup> , X, Y, Z directions/hour
Cooling mode	Natural air cooling
<b>Product certification</b>	
Panel protection grade	IP65 compliant
CE authentication	CE compliant (EN6100-6-4:2007+A1:2011, EN61000-6-2:2005)
Software	
Configuration software	Kinco DTools V4.1 and above

Mechanical Dimensions (Unit: mm)

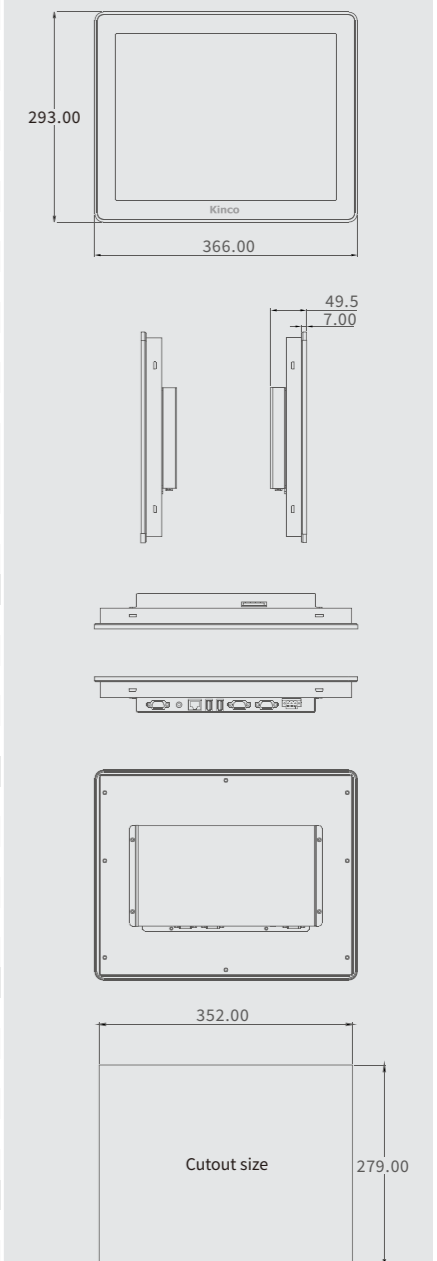

## Split type industrial HMI xF-SiHMI01

- High-end configuration: Cortex-A9 architecture, Main frequency: 1G, 512MB DDR3 + 4GB eMMC;
- HDMI V1.4 Full HD (1,920\*1,080@60Hz) high resolution output;
- Standard configuration: 2 USB hosts, 3 serial ports (COM1 is terminal-type), and one Ethernet port;
- The concept of separating the screen from the host, adaptive to various display devices, such as TV, monitor, projector, etc., through HDMI interface;
- 2-channel digital input (programmable, standard 24V source), 3-channel digital output (programmable, standard 24V source);
- Optional WiFi 802.11b/g/n wireless network and SD card to expand storage capacity;
- Various installation methods: DIN rail mounting (35mm) and VESA rack mounting (75\*75mm).



Model/Specification	xF-SiHMI01
<b>Performance specifications</b>	
Processor	32Bit RISC Cortex-A9 1GHz
Storage	512MB DDR3+4GB eMMC
<b>Interface Configuration</b>	
Display port	1*HDMI V1.4 Full HD (1920*1080@60Hz)
Expandable storage	2*USB HOST
Ethernet	LAN0:10/100Mbps
Communication port	COM0:RS232/RS422/RS485; COM1:RS485;COM2:RS232
IO port	2-channel digital input (programmable, standard 24V source); 3-channel digital output (programmable, standard 24V source)
External power supply	1*DC 24V power supply (same input voltage), current 500mA
<b>Electrical specifications</b>	
Rated power	2.4W
Input power supply	DC12V~DC28V
Allowable loss of power	<3ms
Insulation resistance	Over 50MΩ@500V DC
Hi-pot test	500 VAC 1 minute
<b>Structure specifications</b>	
PCB coating (Yes/No)	None
Shell color	Black
Shell material	Metallic
Shape size	133X104X30.2 mm
Installation	DIN rail mounting (35mm) and VESA rack mounting (75*75mm)
Weight	0.47kg
<b>Environmental specifications</b>	
Operating ambient temperature	-10~55°C
Operating ambient humidity	10~90% RH (noncondensing)
Storage ambient temperature	-30~80°C
Storage ambient humidity	10~90% RH (noncondensing)
Sine vibration test	10~25Hz (2G/30min in X, Y, Z directions)
Cooling mode	Natural air cooling
<b>Product certification</b>	
Panel protection grade	IP 20
CE authentication	CE compliant (EN6100-6-4:2007+A1:2011, EN61000-6-2:2005)
Software	
Configuration software	Kinco DTools V3.5.3 and above

Mechanical Dimensions (Unit: mm)

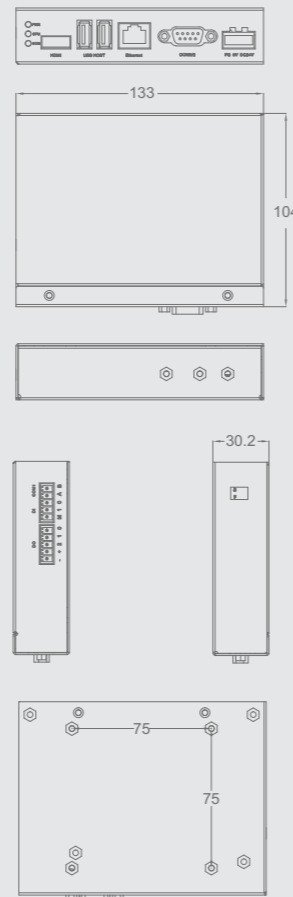

## M2 Series HD and High-performance M2070H/M2070HE

- 7", HD display, 16.77M true color;
- The front panel protection grade is IP65-compliant;
- Buckle-mounted sealing design for waterproofing and oil pollution protection;
- Kinco DTools, a new generation of Kinco configuration software, with powerful function, simple and easy.



Model/Specification	M2070H	M2070HE
<b>Performance specifications</b>		
Display size	7" TFT	
Display area	154.21(H)x85.92(V)	
Resolution	1,024*600 pixels	
Display color	16.77M true color	
Display angle of view	85/85/85/85 (left/right/up/down)	
Contrast ratio	800:1	
Backlight	LED	
Brightness	450cd/m <sup>2</sup>	
Backlight life	More than 30,000 hours	
Touch panel	4-wire precision resistance network (surface hardness: 4H)	
Processor	ARM Cortex-A7 Dual Core 1GHz	
Storage	256MB NAND Flash Memory + 128MB DDR3 Memory	
RTC	Built-in	
Expandable storage	1 USB Host	
Print port	USB host/serial port	
Ethernet	None	LAN0:10/100Mbps
Program download	USB Slave (Micro USB)/U disk	USB Slave (Micro USB)/U disk/Ethernet port
Communication port	COM0:RS232/RS485/RS422 COM1:RS485; COM2: RS232	
<b>Electrical specifications</b>		
Input power supply	DC10.8V~DC28V	
Power consumption	4.2W@DC24V	
Allowable loss of power	<3ms	
Insulation resistance	Over 50MΩ@500V DC	
Hi-pot test	500 VAC 1 minute	
<b>Structure specifications</b>		
PCB coating (Yes/No)	None	
Shell material	Engineering plastic	
Shape size	204×150×37.2mm	
Cutout size	192×138mm	
Weight	Approx. 0.5kg	
<b>Environmental specifications</b>		
Operating ambient temperature	0~50°C	
Operating ambient humidity	10~90% RH (noncondensing)	
Storage ambient temperature	-20~60°C	
Storage ambient humidity	10~90% RH (noncondensing)	
Sine vibration test	10~500Hz, 30m/S <sup>2</sup> , X, Y, Z directions/hour	
Cooling mode	Natural air cooling	
<b>Product certification</b>		
Panel protection grade	IP65 compliant (4208-93)	
CE authentication	CE compliant (EN61000-6-4:2007+A1:2011, EN61000-6-2:2005)	
Software		
Configuration software	Kinco DTools V4.0 and above	

Mechanical Dimensions (Unit: mm)

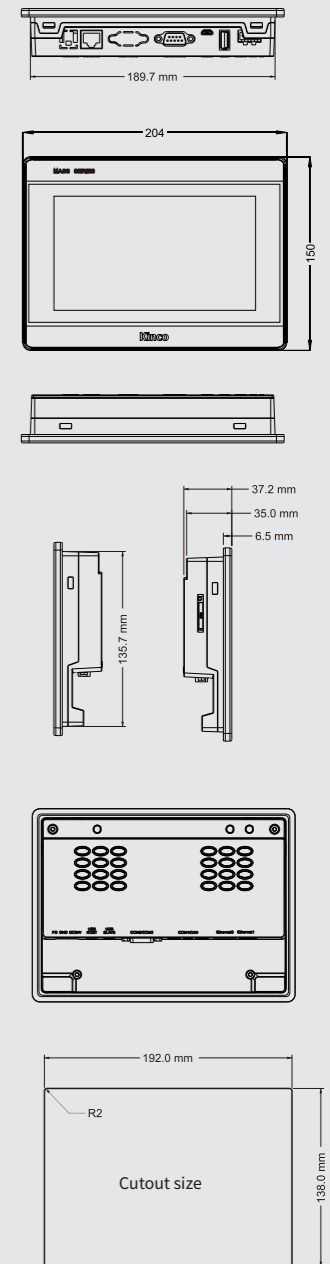

## M2 Series HD and High-performance M2100/M2100E

- Industrial-grade multi-core CPU;
- 10.1" display, 16.2M true color;
- 256MB NAND Flash Memory+128MB DDR3 Memory;



Model/Specification	M2100	M2100E
<b>Performance specifications</b>		
Display size	10.1" TFT	
Display area	222.72(H)x125.28(V)	
Resolution	1,024*600 pixels	
Display color	16.2M true color	
Display angle of view	85/85/85/85 (left/right/up/down)	
Contrast ratio	500:1	
Backlight	LED	
Brightness	300cd/m <sup>2</sup>	
Backlight life	More than 30,000 hours	
Touch panel	4-wire precision resistance network (surface hardness: 4H)	
Processor	ARM Cortex-A7 Dual Core 1GHz	
Storage	256MB NAND Flash Memory + 128MB DDR3 Memory	
RTC	Built-in	
Expandable storage	1 USB Host	
Print port	USB host/serial port	
Ethernet	None	LAN0:10/100Mbps
Program download	USB Slave (Micro USB)/U disk	USB Slave (Micro USB)/U disk/Ethernet port
Communication port	COM0:RS232/RS485/RS422 COM1:RS485; COM2: RS232	
<b>Electrical specifications</b>		
Input power supply	DC10.8V~DC28V	
Power consumption	6W@DC24V	
Allowable loss of power	<3ms	
Insulation resistance	Over 50MΩ@500V DC	
Hi-pot test	500 VAC 1 minute	
<b>Structure specifications</b>		
PCB coating (Yes/No)	None	
Shell material	Engineering plastic	
Shape size	280x193x36mm	
Cutout size	260x179mm	
Weight	Approx. 0.9kg	
<b>Environmental specifications</b>		
Operating ambient temperature	0~50°C	
Operating ambient humidity	10~90% RH (noncondensing)	
Storage ambient temperature	-20~60°C	
Storage ambient humidity	10~90% RH (noncondensing)	
Sine vibration test	10~500Hz, 30m/S <sup>2</sup> , X, Y, Z directions/hour	
Cooling mode	Natural air cooling	
<b>Product certification</b>		
Panel protection grade	IP65 compliant (4208-93)	
CE authentication	CE compliant (EN61000-6-4:2007+A1:2011, EN61000-6-2:2005)	
<b>Software</b>		
Configuration software	Kinco DTools V4.0 and above	

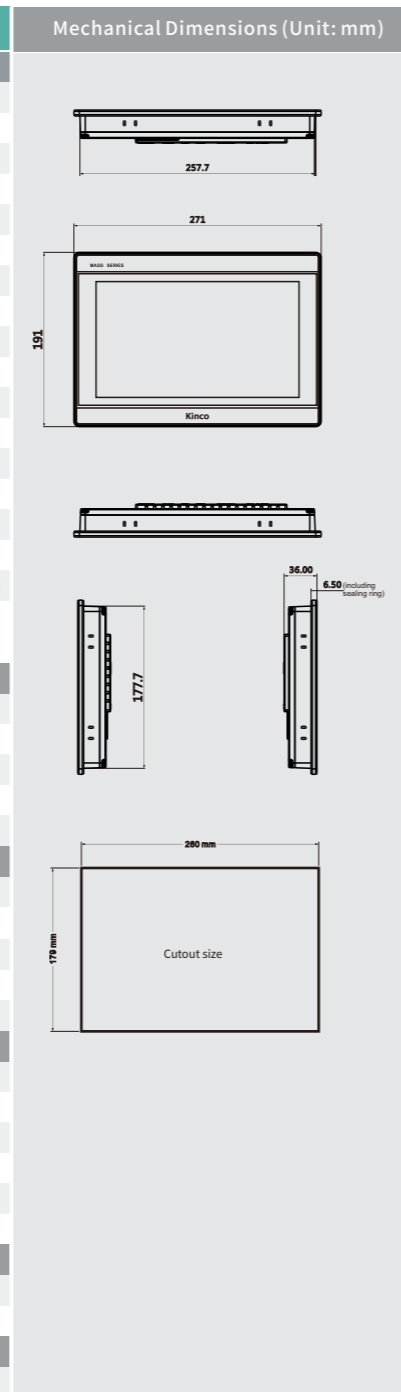

## GR Series Rear **Rear-installation without front shell**

- The GR series products adopt the rear-installation fixation method, which enables them to perfectly fit the surface of the equipment and be integrated with the equipment



Model	GR043	GR070E	GR100E
<b>Performance specifications</b>			
Display size	4.3" TFT	7" TFT	10.1" TFT
Resolution	480 × 272 pixels	800 × 480 pixels	1,024 × 600 pixels
Display color	16.77M true color		
Brightness	450cd/m <sup>2</sup>	250cd/m <sup>2</sup>	400cd/m <sup>2</sup>
Backlight	LED		
Touch panel	4-wire precision resistance network (surface hardness: 4H)		
LCD life	More than 30,000 hours		
Processor	ARM RISC 32Bit 800MHz		
Storage	256MB NAND Flash Memory + 128MB DDR3 Memory		
RTC	RTC		
Expandable storage	1 USB Host		
Print port	USB/serial port		
Ethernet	Not supported	LAN0:10/100Mbps	
Program download	USB Slave (Micro USB)/U disk	USB Slave (Micro USB)/U disk/Ethernet port	
Communication port	COM0:RS232/RS485/RS422; COM2: RS232	COM0:RS232/RS485/RS422; COM2: RS232	
<b>Electrical specifications</b>			
Input power supply	DC10.8V~DC28V		
Power consumption	2W@DC24V	3.6W@DC24V	6W@DC24V
Allowable loss of power	<3ms		
Insulation resistance	Over 50MΩ@500V DC		
Hi-pot test	500 VAC 1 minute		
<b>Structure specifications</b>			
PCB coating (Yes/No)	None		
Shell color	-		Metallic gray
Shell material	Metallic		
Shape size	128 × 75 × 27mm	190.4 × 110 × 30mm	275.6 × 163.6 × 32mm
Cutout size	107.7 × 69.4 mm	166.7 × 101.6 mm	236.9 × 146.3 mm
Weight	0.2kg	0.3kg	0.9kg
<b>Environmental specifications</b>			
Operating ambient temperature	0~50°C		
Operating ambient humidity	10~90% RH (noncondensing)		
Storage ambient temperature	-20~60°C		
Storage ambient humidity	10~90% RH (noncondensing)		
Sine vibration test	10~500Hz, 30m/S <sup>2</sup> , X, Y, Z directions/hour		
Cooling mode	Natural air cooling		
<b>Product certification</b>			
Front panel protection grade	IP20 compliant		
CE authentication	CE compliant (EN61000-6-4:2007+A1:2011, EN61000-6-2:2005)		
<b>Software</b>			
Configuration software	Kinco DTools V3.5.3 and above		

Note: GR043 is replacement of MT4043R; GR070E is replacement of MT4070R and MT4070ER; GR100E is replacement of MT4100ER.

# RT070 Dedicated Handheld Terminal

- Basic specification: 7" TFT, 800×480 pixels, 16.77M true color;
- Standard configuration: One 3-option switch, and one emergency stop switch; optional 3-position enable switch for occasions with high security requirements;
- Mobile operation: Handheld terminal, Standard configuration: 5m cable;
- Simple installation: Support FDM standard (hole spacing: 75×75mm) rack mounting;
- Intimate services: Customized services can be provided according to the actual applications of customers.



Model	RT070
<b>Performance specifications</b>	
LCD size	7" TFT
Resolution	800×480 pixels
Display color	16.77M true color
Brightness	250cd/m <sup>2</sup>
Backlight	LED
Touch panel	4-wire precision resistance network (surface hardness: 4H)
LCD life	50,000 hours
Programmable LED	2
Emergency stop switch	1
3-option switch	1
CPU	ARM RISC 32Bit 800 MHz
Storage	128MB NAND Flash Memory + 128MB DDR3 Memory
RTC & recipe storage	RTC + 256KB
Expandable storage	1 USB Host
Serial port	1 RS485-2/RS232
Ethernet	None
Program download	Serial port (RS232), USB host
Communication port	RS485-2, RS232
<b>Electrical specifications</b>	
Input power supply	DC16V~DC32V, built-in isolated
Power consumption	8W@DC24V
Allowable loss of power	<3ms
Insulation resistance	Over 50MΩ@500V DC
Hi-pot test	500V AC 1 minute
<b>Structure specifications</b>	
PCB coating (Yes/No)	None
Shell color	Black
Shell material	Engineering plastic
Shape size	220×156×45mm
Installation	Rack mounting and suspension mounting
Weight	None
<b>Environmental specifications</b>	
Operating ambient temperature	0~50°C
Operating ambient humidity	10~90% RH (noncondensing)
Storage ambient temperature	-10~60°C
Storage ambient humidity	10~90% RH (noncondensing)
Sine vibration test	10~500Hz, 30m/S <sup>2</sup> , X, Y, Z directions/hour
Cooling mode	Natural air cooling
<b>Product certification</b>	
Protection grade of complete machine	The front panel meets the IP65 requirements, and the complete machine meets the IP62 requirements
CE authentication	CE compliant (EN61000-6-4:2007+A1:2011, EN61000-6-2:2005)
<b>Software</b>	
Configuration software	Kinco DTools V3.5.3 and above

Mechanical Dimensions (Unit: mm)

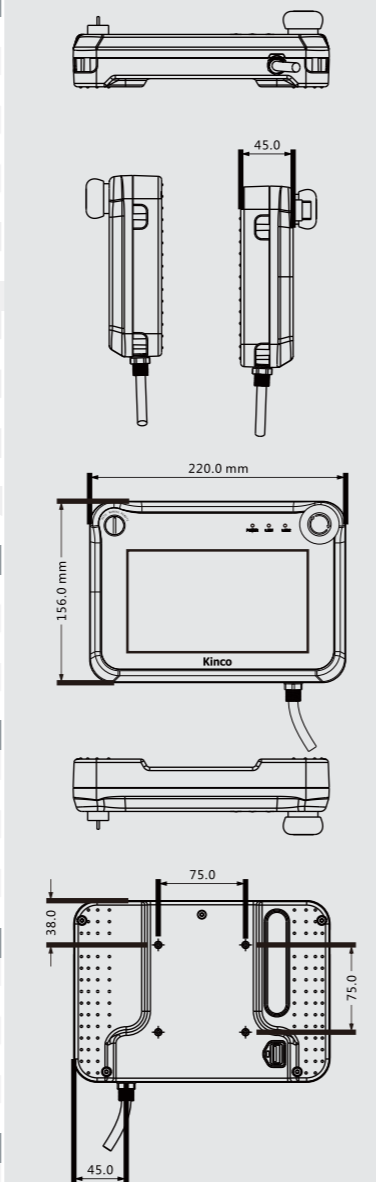

# SZ7G Series Dedicated Handheld Terminal

- Basic specification: 7" TFT, 800×480 pixels, 16.77M true color;
- Standard configuration: 3-option switch, emergency stop switch, holding switch, 10 custom buttons, and 2 indicators;
- Practical design: both buttons and touch control, more applications, more flexible choices;
- Mobile operation: Handheld terminal, Standard configuration: 5m cable;
- Various installation methods: Suspension mounting, rack mounting, etc.



Model	SZ7G	SZ7GS	SZ7GE	SZ7GES
<b>Performance specifications</b>				
LCD size	7" TFT			
Resolution	800×480 pixels			
Display color	16.77M true color			
Brightness	250 cd/m <sup>2</sup>			
Backlight	LED			
Touch Screen	4-wire precision resistance network (surface hardness: 4H)			
LCD life	50,000 hours			
Programmable button	10			
Programmable LED	2			
Emergency stop switch	1			
3-option switch	1			
Handhold switch	None	1	None	1
Processor	ARM RISC 32Bit 800MHz			
Storage	128MBNAND Flash Memory + 128MB DDR3 Memory			
RTC	RTC			
Expandable storage	1*USB Host			
Ethernet	None	None		LAN0:10/100Mbps
Program download	Serial port (RS232), U disk		U disk, Ethernet port	
Communication port	RS485-2, RS232		Ethernet port	
<b>Electrical specifications</b>				
Input power supply	DC16V~DC32V, built-in isolated			
Power consumption	8W@DC 24V			
Allowable loss of power	<3ms			
Insulation resistance	Over 50MΩ@500V DC			
Hi-pot test	500V AC 1 minute			
Cable length	5m			
<b>Structure specifications</b>				
Weight	3kg			
PCB coating (Yes/No)	None			
Shell color	Black			
Shell material	Engineering plastic			
Shape size	220×156×45 mm			
Installation	Rack mounting and suspension mounting			
<b>Environmental specifications</b>				
Operating ambient temperature	0~50°C			
Operating ambient humidity	10~90% RH (noncondensing)			
Storage ambient temperature	-10~60°C			
Storage ambient humidity	10~90% RH (noncondensing)			
Sine vibration test	10~500Hz, 30m/S <sup>2</sup> , X, Y, Z directions/hour			
Cooling mode	Natural air cooling			
<b>Product certification</b>				
Protection grade of complete machine	The front panel meets the IP65 requirements, and the complete machine meets the IP62 requirements			
CE authentication	CE compliant (EN61000-6-4:2007+A1:2011, EN61000-6-2:2005)			
<b>Software</b>				
Configuration software	Kinco DTools V3.5.3 and above			

Mechanical Dimensions (Unit: mm)

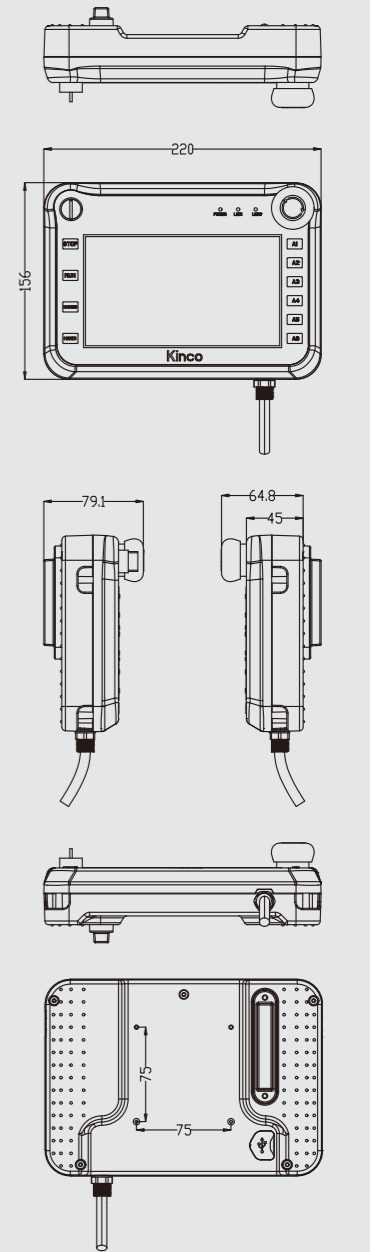

# CZ6 HMI designed for use in severe environments

- The outer shell adopts high thermostability and high intensity uvioresistant material;
- LCD with a wide range of operating temperature: -20°C~70°C;
- Wider voltage input range: DC9V~DC36V;
- Highly shockproof performance of screen due to the excellent internal structure design and the application of silicone pad;
- Military-grade encoder switch, with longer life and more stable performance;
- Rich in communication ports and CAN ports, support CANopen/CAN J1939/serial port/RS232/RS485;
- IP65-complaint waterproof complete machine (USB ports required to be covered).



Model	CZ6
<b>Performance specifications</b>	
LCD size	5.7" TFT
Resolution	640*480 pixels
Display color	65,536 color
Brightness	700cd/m <sup>2</sup>
Backlight	LED
LCD life	50,000 hours
Processor	ARM RISC32Bit 800MHz
Storage	256MB FLASH+256MB DDR3
RTC	RTC
Expandable storage	1 USB Host
Print port	Serial port/USB host
Ethernet	Not supported
Program download	1*USB2.0 quick download/serial port
Communication port	COM0: RS485, COM2: RS232, 1*CANopen
Expandable interface	Not supported
<b>Electrical specifications</b>	
Input power supply	DC9V~DC36V, built-in isolated
Power consumption	10W@DC24V
Allowable loss of power	<3ms
Insulation resistance	Over 50MΩ@500V DC
Hi-pot test	500V AC 1 minute
<b>Structure specifications</b>	
PCB coating (Yes/No)	None
Shell color	Navy blue
Shell material	Engineering plastic
Shape size	180.3x133.9x70.7mm
Installation	171x125mm
Weight	1kg
<b>Environmental specifications</b>	
Operating ambient temperature	-20°C~70°C
Operating ambient humidity	10~90% RH (noncondensing)
Storage ambient temperature	-30°C~80°C
Storage ambient humidity	10~90% RH (noncondensing)
Sine vibration test	10~500Hz, 30m/S <sup>2</sup> , X, Y, Z directions/hour
Cooling mode	Natural air cooling
<b>Product certification</b>	
Protection grade	IP65-complaint waterproofing for complete machine (USB ports required to be covered)
CE authentication	CE compliant (EN61000-6-4:2007+A1:2011, EN61000-6-2:2005)
<b>Software</b>	
Configuration software	Kinco DTools V3.5.3 and above

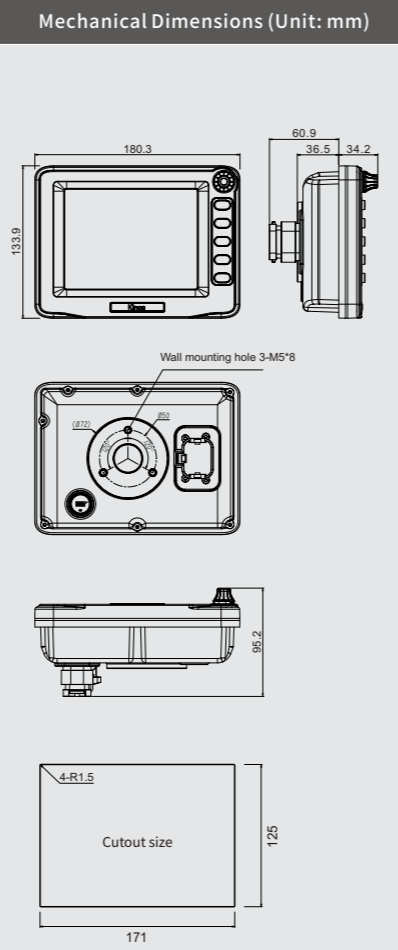

Note: CZ6 is a replacement model for KG5300T, KG5509T, and KM5303T.

# F10N Waterproof Dedicated Touch Screen

- IP65-compliant shockproof and waterproof rack mounted for complete machine
- Fit the quick experience with the application
- HD display, Main frequency: 800MHz
- Resolution up to 1280x800 pixels, simple and easy
- U disk update, stylish appearance, ultra-thin and ultra-narrow border
- Integrate with industry color matching



Model	F10N
<b>Performance specifications</b>	
Display module	10.1" TFT LCD
Display color	16.77M
Resolution	1280×800 pixels
Backlight	LED
Brightness	250cd/m <sup>2</sup>
LCD life	50000H
Touch panel	4-wire precision resistance network (surface hardness: 4H)
CPU	ARM RISC32 Bit 800MHz
Storage	128MB FLASH+128MB SDRAM
RTC & recipe storage	512KB + RTC
Expandable storage	1 USB Host
Print port	Serial port
Ethernet	Not supported
Program download	U disk
Communication port	COM0: PLC RS485-2W; COM2: PC/PLC RS232
<b>Electrical specifications</b>	
Input power supply	DC18V~DC28V, built-in isolated
Power consumption	8W@DC24V
Allowable loss of power	<3ms
Insulation resistance	Over 50MΩ@500V DC
Hi-pot performance	500V AC 1 minute
<b>Structure specifications</b>	
Shell color	Metallic gray
Shell material	Engineering plastic
Shape size	250×167×28.4mm
Cutout size	Standard rack mounting
Weight	0.91kg
<b>Environmental specifications</b>	
Operating temperature	0~50°C
Operating humidity	10~90% RH (noncondensing)
Storage temperature	-10~60°C
Storage humidity	10~90% RH (noncondensing)
Shockproof performance	10~500Hz, 30m/S <sup>2</sup> , X, Y, Z directions/hour
Cooling mode	Natural air cooling
<b>Product certification</b>	
Protection grade of complete machine	IP65 compliant (4208-93)
CE authentication	CE compliant (EN61000-6-4:2007+A1:2011, EN61000-6-2:2005)
Compatibility required by FCC	FCC ClassA compliant
<b>Software</b>	
Configuration software	Kinco DTools V3.5.3 and above

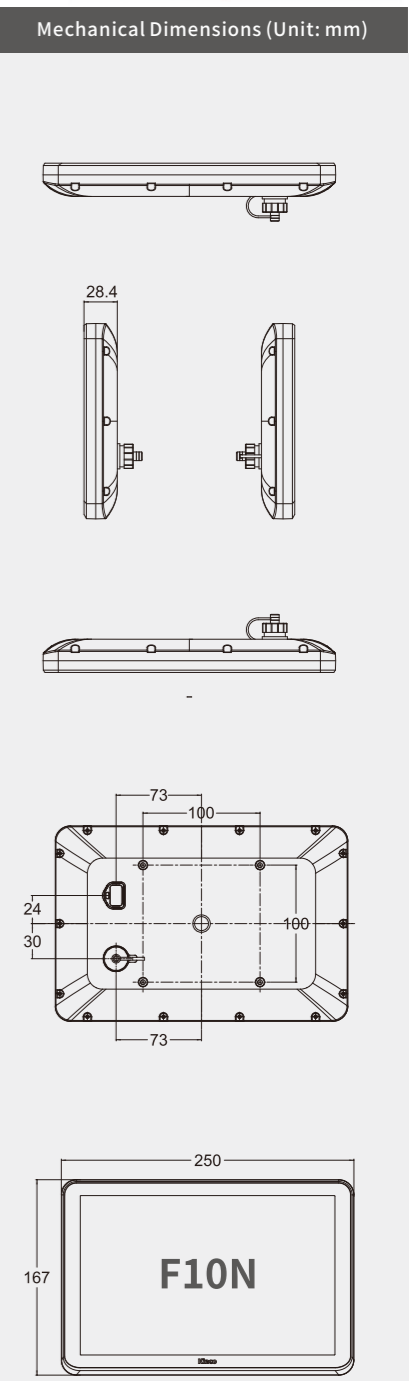

Note: F10N is replacement of F7, F10 and F10W.

# G100E-LRF

## Waterproof Dedicated Touch Screen

IP65-compliant shockproof and waterproof complete machine  
Three download methods, efficient and convenient  
With IoT function built-in, support teleservice



Model	G100E-LRF
<b>Performance specifications</b>	
Display size	10.1" TFT
Display area	222.72(W)x125.28(H)
Resolution	1,024*600 pixels
Display color	16.2M true color
Contrast ratio	500:1
Backlight	LED
Brightness	300cd/m <sup>2</sup>
Backlight life	More than 30,000 hours
Touch panel	4-wire precision resistance network (surface hardness: 4H)
Processor	ARM RISC 32Bit 792MHz
Storage	128MB NAND Flash Memory + 128MB DDR3 Memory
RTC	Built-in
Expandable storage	1 USB Host
Print port	USB host/serial port
Ethernet	LAN0:10/100 Mbps
Program download	USB Slave/U disk/Ethernet port
Communication port	COM0:RS232/RS485;COM2:RS232
<b>Electrical specifications</b>	
Input power supply	DC10V~DC28V
Power consumption	6W @DC24V
Allowable loss of power	<3ms
Insulation resistance	Over 50MΩ@500V DC
Hi-pot test	500 VAC 1 minute
<b>Structure specifications</b>	
Shell material	Engineering plastic
Shape size	280×193×36mm
Cutout size	260×180mm
Weight	0.9kg
<b>Environmental specifications</b>	
Operating temperature	0~50°C
Operating humidity	10~90% RH (noncondensing)
Storage temperature	-20~60°C
Storage humidity	10~90% RH (noncondensing)
Shockproof performance	10~500Hz, 30m/S <sup>2</sup> , X, Y, Z directions/hour
Cooling mode	Natural air cooling
<b>Product certification</b>	
Protection grade of complete machine	IP65 compliant (4208-93)
CE authentication	CE compliant (EN61000-6-4:2007+A1:2011, EN61000-6-2:2005)
<b>Software</b>	
Configuration software	Kinco DTools V4.1 and above

Mechanical Dimensions (Unit: mm)

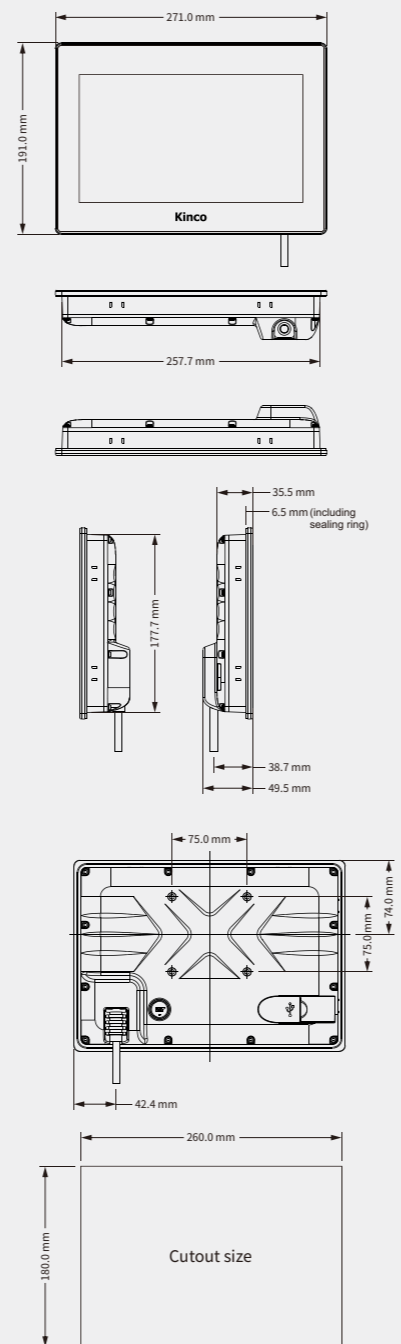

# G100E2-WIFI-PR01

## Waterproof Dedicated Touch Screen

- The operating temperature of the whole machine is -20~70°C
- Standard dual network ports +WiFi for remote debugging
- The main board is sprayed with three anti-paint to resist condensation
- Full metal shell, strong anti-interference ability
- Full fit process, look and feel similar to capacitive screen



Model	G100E2-WIFI-PR01
<b>Performance specifications</b>	
Display size	10.1" TFT
Display area	222.72*125.28mm
Resolution	1024*600 pixels
Display color	16.7M
Display angle of view	85/85/85/85(left/right/up/down)
Contrast ratio	800:1
Backlight	LED
Brightness	250cd/m <sup>2</sup>
Backlight life	> 30000hours
Touch panel	4-wire precision resistance network(surface hardness: 3H)
Processor	ARM RISC 32Bit 800MHz
Storage	256MB NAND Flash Memory + 256MB DDR3 Memory
RTC	Built-in
Expandable storage	1 USB Host
Print port	USB host/serial port
Ethernet	LAN0:10/100Mbps LAN1:10/100Mbps
Program download	USB Slave (Micro USB)/U disk/Ethernet port
Communication port	COM0:RS232/485/422;COM1:485/422/CAN;COM2:RS232;
<b>Electrical specifications</b>	
Input power supply	DC18V~DC28V, built-in isolated
Power consumption	15W@DC24V
Allowable loss of power	<3ms
Insulation resistance	Over 50MΩ@500V DC
Hi-pot test	500V AC 1 minute
<b>Structure specifications</b>	
PCB coating (Yes/No)	Yes
Shell material	Metallic
Shape size	166 × 254 × 32.6 mm
Cutout size	192 × 138 mm
Weight	1.65 kg
<b>Environmental specifications</b>	
Operating ambient temperature	-20 ~70 °C
Operating ambient humidity	10 ~90 % RH (noncondensing)
Storage ambient temperature	-30 ~80 °C
Storage ambient humidity	10 ~90 % RH (noncondensing)
Sine vibration test	10 ~500 Hz, 30 m/s <sup>2</sup> , X, Y, Z directions/1 hour
Cooling mode	Natural air cooling
<b>Product certification</b>	
Panel protection grade	IP65 compliant (4208-93)
CE authentication	CE compliant (EN61000-6-4:2019,EN61000-6-2:2019)
<b>Software</b>	
Configuration software	Kinco DTools V4.1 and above

Mechanical Dimensions (Unit: mm)

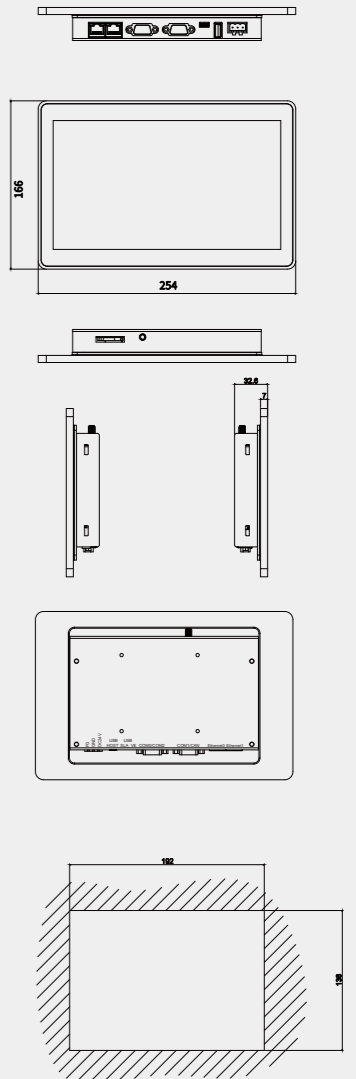

## Configuration software: **Kinco DTools**

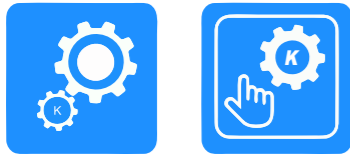

Kinco HMI with a new generation of free configuration software: Kinco DTools. Support eight language versions, including simplified Chinese, traditional Chinese, English, Korean, German, Russian, Turkish and Arabic. Configuration design content supports all installed fonts on your computer system.

The IoT function supports Cloud data acquisition and storage; supports terminal interoperation from screen (VNC) to screen or from screen to computer, or mobile phone, etc.; supports payment by installments, PDF browsing, operation log and other convenient control design.

The wizard guide interface adopts humanized design, making what you see is what you get, so that you can get started quickly.



**IoT function**  
Manufacturers  
or end users  
MQTT, OPCUA, HJ212, HTTP, etc.

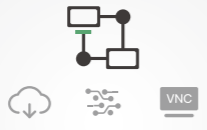

**Teleservice function**  
Remote desktop, remote penetration,  
remote download

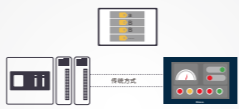

**Traditional method**  
Tag communication  
OMRON, Siemens, Bottu, codesys, etc.



**Files can be uploaded and downloaded freely**  
FTP Client & recipe area browsing  
File transfer with external storage devices

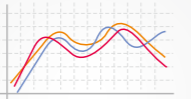

**Reports and charts**  
Tendency charts, XY graphs,  
data reports, etc.



**Email**  
Alarm push, transfer of  
CSV/PDF and other files

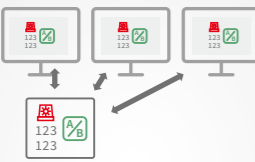

**Template library**  
With custom grouped controls,  
support import and export

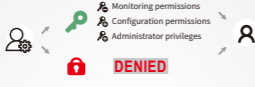

**Level password management**  
16 levels of users set  
16 levels of users set  
Different screens can be seen by  
using different passwords

**User-privilege management**  
Different display or operation  
permissions for different users,  
convenient for multi-user management



**CSV file encrypted-export**  
Improve the confidentiality of  
historical data, recipe, operation log,