

PROVEN PERFORMANCE

Customers in over 50 countries and in diverse markets and sectors.

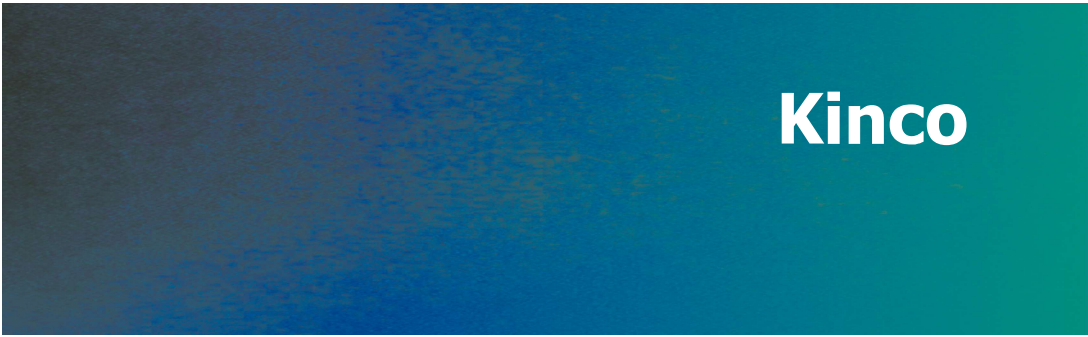

VFD

 Kinco KC100 high performance vector inverter



Kinco® Automation
en.kinco.cn Email: sales@kinco.cn

(All trademarks and logos in this brochure are property of and registered by their respective owners.)

K1E59-2407 K1E62

About us

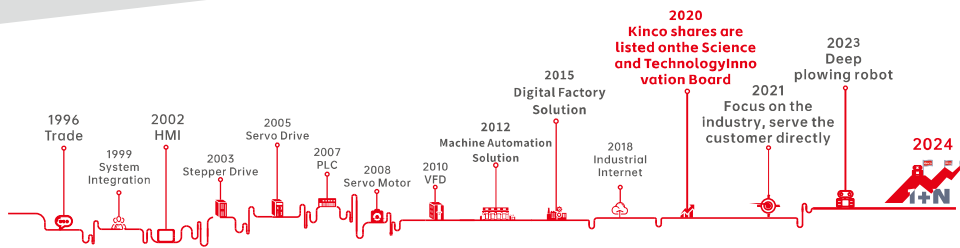

Kinco was founded in 1996, and successfully listed on the Shanghai Stock Exchange in 2020 (abbreviated name: Kinco share, stock code 688160), which is a high-tech, specialized and sophisticated enterprise that attaches great importance to independent research and development and innovation, mainly engaged in the research and development, production, sales and related technical services of industrial automation and robot core components and digital factory hardware and software. It is a leading supplier of automation control, robot power and digital factory solutions in China.

After years of continuous research and development and innovation, Kinco has established a complete product line with independent intellectual property rights, covering a series of products from machine iot to human-machine interaction, control, drive and execution, which are widely used in robots, medical equipment, logistics equipment, packaging equipment, food equipment, clothing equipment, environmental protection equipment, etc. New energy equipment, rail transit equipment and other automation equipment industry.

Based on the comprehensive industrial automation and digital technology platform, the company has in-depth application scenarios in the robot industry, providing display, control, drive and other multi-dimensional solutions for industrial mobile robots, collaborative robots, industrial robots, pan-service robots, and bionic robots. Through the insight of the industry pain points, deep links with robot customers, combined with the advantages of product research and development, the company continues to innovate, and launches industry-leading low-voltage servo products for mobile robots, integrated servo wheel, frameless torque motor for collaborative robots, robot human-machine interfaces, robot controllers and other products. The company has formed a relatively complete robot core parts capability, and after nearly 10 years of hard work in the robot industry, it has become a leading enterprise in the field of mobile robot low-voltage servo, and has a high brand influence in the industry.

Kinco has four research and development centers in Shanghai, Shenzhen, Changzhou and Chengdu, and two manufacturing bases in Shenzhen and Changzhou, a total of 10+ domestic marketing centers, 100+ domestic service providers, 40+ global partners, and products are exported to 70+ countries overseas. In terms of after-sales service, Kinco has established after-sales service centers in Shanghai, Shenzhen and Changzhou.

KC100 series inverter

High performance vector inverter

KC100 series inverter is a cost-effective product developed by Kinco based on a new technology platform. KC100 adopts narrow book-shape design, European crimping terminal and independent air duct design, which has many advantages such as convenient installation, convenient wiring, excellent heat dissipation, excellent performance and comprehensive protection. KC100 is systematic, process-oriented and strict in the development process of software, hardware and structure, paying attention to details and user experience. In the production and manufacturing process, KC100 relies on a complete quality process system to realize automatic tooling testing of all veneers and complete machines to ensure product quality.



Voltage level

Single-phase 220V model
0.4-2.2kW

Three-phase 380V/440V
0.75-7.5kW

Telecommunication

Support RS485 standard Modbus

Terminal configuration

4 *digital inputs

1 *analog input

1* relay output

1* analog output

1 *digital output

1*RS485 communication

Industry applications

It can be widely used in sewage treatment, manufacturing production lines, fan ventilation systems, logistics and transportation, air conditioner cooling systems, woodworking machinery, and various automated production equipment and other industries.

Contents

- 02 Product Features
- 06 Naming rules & Parameters
- 07 Technical Specifications
- 08 Size drawing
- 09 Terminal wiring diagram & Function Description
- 10 Keyboard Operations
- EMC Filter selection

Product Feature

Product highlights

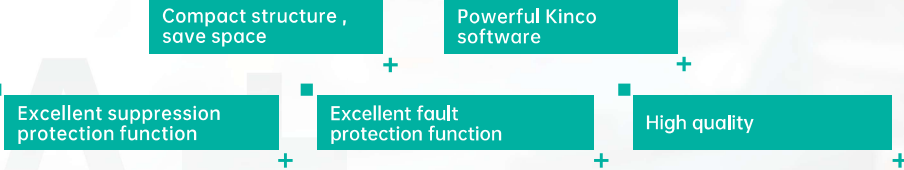

Compact structure, save space

- Narrow book-shape design, as small as 65mm, can be rail, vertical mounted; 20% less space than previous generations;
- European crimping terminal, 10 terminals without tightening screws, can improve assembly efficiency by 30%;
- Support network port connected to external keyboard and use standard MODBUS communication protocol and scheme.

Space Savings of
20%

Network port
external keyboard



Product Feature

Powerful Kinco software

- Various frequency channel selections such as panel, analog, communication, pulse, PID, multi-speed, etc.
- Built-in AVR, over-modulation, instantaneous non-stop and other functional design, can adapt to complex grid environment;
- High-performance VF control algorithm that can achieve full speed range of rated frequency (except zero speed) with 150% load stable operation;
- High-performance SVC control for stable operation with 150% load over the full speed range of the rated frequency.

Open loop vector stable operation with 150% load in full speed range

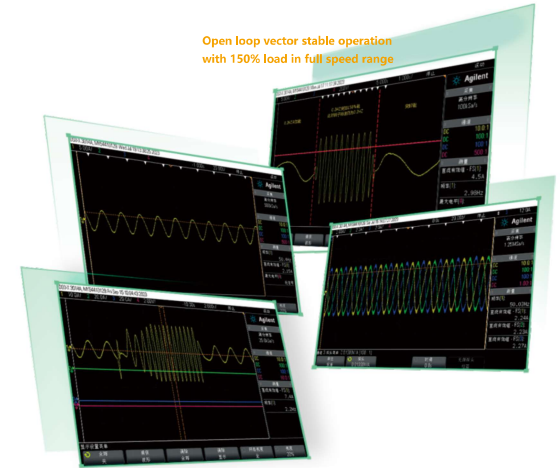

New high-performance vt control algorithm, stable operation at 0.1Hz with 150% load

Excellent suppression protection function

- **Overcurrent suppression protection** : real-time current monitoring, automatically limit the current to no more than the overcurrent suppression point;
- **Overvoltage suppression protection** : When no brake resistor is connected, the operating frequency is automatically adjusted or the bus voltage rise is suppressed by flux braking;
- **Undervoltage suppression protection (instantaneous non-stop)** : It can realize the function of instantaneous power loss without stopping;
- **Wave-by-wave current limiting** : When the sudden load or abnormal conditions such as momentary spikes in the current occurs, it will trigger the wave-by-wave current limit protection, which can limit the rise of the current to a certain extent, so that the current does not exceed the protection value of the inverter, and avoid reporting overcurrent fault and shutdown.
- **Heat dissipation treatment** : Independent air duct design, close to IGBT device, which can make cooling more efficiently, while the software built-in automatic reduction of carrier frequency according to temperature rise.

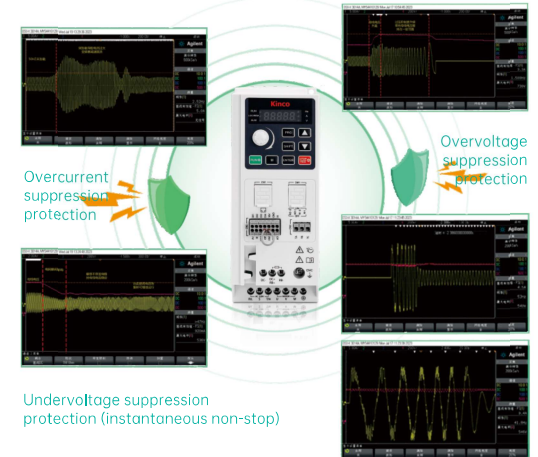

Wave-by-wave current limiting

Product Feature

Excellent fault protection function

- Overvoltage, overcurrent fault protection;
- Input phase loss: Detect input phase loss based on bus voltage fluctuations. When phase loss occurs, a certain load is required to detect it;
- Output phase loss: Output phase loss fault can be quickly detected before and during operation;
- Phase to phase short circuit and short circuit to ground fault: quickly detected within 20ms before operation;
- Inverter module overtemperature, parameter self-learning failure, current detection failure.



High quality

- Fast delivery:**
Kinco digital smart factory, using a more advanced overall lean production layout and end-to-end quality management system, high production efficiency, to ensure fast delivery;
- 24h instantaneous response:**
Attach importance to customer experience and respond quickly to customer needs through multiple channels of quality service.



Naming Rules & Parameters

KC100 series inverter naming rules

KC100 - 2 S - 01R5 G / 02R2 L

① ② ③ ④ ⑤ ④ ⑤

①-Series

KC100:KC100 Series

③-Voltage level

S: Single-phase 200V~240V
T: Three-phase 380V~480V

⑤-Adaptive load

G: Heavy load
L: Light load

②-Input voltage

2: AC220V
4: AC380V
5: AC440V

④-Adaptive motor power

01R5:1.5KW
02R2:2.2KW
...
05R5:5.5KW

Note: R stands for decimal point

KC100 series inverter specifications and technical parameters

Inverter type	power capacity kVA	Input Current A	Output Current A	Adaptive motor kW
Single-phase 200V ~ 240V 50Hz/60Hz				
KC100-2S-0R40G/0R75L	1.0/1.5	5.3/8.2	2.5/4.0	0.4/0.75
KC100-2S-0R75G/01R5L	1.5/3.0	8.2/14.0	4.0/7.5	0.75/1.5
KC100-2S-01R5G/02R2L	3.0/4.0	14.0/23.0	7.5/10.0	1.5/2.2
KC100-2S-02R2G/03R7L	4.0/6.4	23.0/32.0	10.0/16.0	2.2/3.7
Three-phase 380V ~ 480V 50Hz/60Hz				
KC100-4T/5T-0R75G/01R5L	1.5/3.0	3.4/5.0	2.3/3.7	0.75/1.5
KC100-4T/5T-01R5G/02R2L	3.0/4.0	5.0/5.8	3.7/5.5	1.5/2.2
KC100-4T/5T-02R2G/03R7L	4.0/5.9	5.8/10.5	5.5/8.8	2.2/3.7
KC100-4T/5T-03R7G/05R5L	5.9/8.5	10.5/14.5	8.8/13.0	3.7/5.5
KC100-4T/5T-05R5G/07R5L	8.5/11.0	14.5/20.5	13.0/17.0	5.5/7.5

Technical Specification

KC100 series inverter technical specification

Item	Specification		
Power Input	Rated voltage, Rated frequency	2S: single-phase 200V~240V 50Hz/60Hz; 4T/5T: Three-phase 380V~480V 50Hz/60Hz	
	Allowable fluctuation range of voltage	-15~10%	
	Allowable fluctuation range of frequency	± 5%	
Output	Output voltage	0~Input voltage	
	Maximum output frequency	600Hz	
	Overload capacity	60s at 150% the rated current, 3s at 180% rated current	
Main control performance	Motor control mode	V/F control, Sensorless vector control (SVC), voltage frequency separation control	
	Modulation mode	Space Vector Pulse Width Modulation	
	Carrier frequency	0.5 kHz ~12.0 kHz	
	Speed range	Open-loop vector control: rated load 1:200	
	Startup torque	Open-loop vector control: 150% rated torque at 0.5Hz	
	Torque response	Open-loop vector control: < 20ms	
	Frequency accuracy	Digit setting: maximum frequency x (± 0.01%); Analog setting: Max. frequency x (± 0.2%)	
	Frequency resolution	Digital setting: 0.01Hz; Analog setting: maximum frequency x 0.1%	
	Torque boost	Automatic torque improved ;manual torque improved 0.1%~30%	
	Dc braking ability	Starting frequency: 0.00Hz ~ maximum frequency; Braking time: 0.0s ~ 60.0s; Brake current value: 0% ~ 150% rated current	
	V/F curve	Four Methods: multi-point V/F curve; Reduced torque characteristic curve;	
	Acceleration/ deceleration curve	Straight-line or S-curve acceleration/deceleration; Four groups of acceleration/deceleration time	
	multi-speed running	The product supports up to 8 speeds with the control terminal	
	Built-in PID	The function facilitates closed-loop control of process control.	
	Basic function of product	Auto voltage regulation(AVR)	When the mains voltage changes, the output voltage keeps constant automatically.
Overvoltage/overcurrent stall control		The function limits the current and voltage automatically during operation to prevent frequent trips caused by overvoltage or overcurrent.	
Fast current limit		The function helps minimize overcurrent faults.	
Power dip ride through		Load regenerative energy compensates for voltage reduction during instantaneous power failure, allowing the AC drive to continue operating for a short time.	
Running command		Running commands can be given through the operating panel, control terminal, or serial port communication, which can be switched over in various ways.	
Frequency reference		Digital, analog voltage, analog current, pulse and communication all have set.	
Auxiliary frequency reference		It can implement fine tuning of the auxiliary frequency and frequency synthesis.	
Input terminals		4*digital input terminals, 1 of which supports high-speed pulse input up to 50kHz 1*analog input terminal, support 0 ~ 10V/0 ~ 20mA input	
Output terminals		1*relay output terminal, including normally closed and normally open sub; 1*analog output terminal, support 0 ~ 10V voltage output 1*digital output terminal, 0.1kHz~50kHz pulse square wave signal output, capable of outputting physical quantities such as set frequency and output frequency 1*RS485 communication	
Network Port		External keyboard interface	
Keyboard display		LED display	Single row 5-digit digital tube, with the same built-in keyboard and external keyboard
		Parameter copy	The external keyboard supports uploading and downloading the functional parameter information of the inverter to achieve fast parameter setting
		Condition monitoring	Can display setting frequency, output frequency, output voltage, output current and other more than 40 state parameters
Environment		Fault Alarm	Overvoltage, undervoltage, overcurrent, short circuit, phase loss, overload, overheating, etc
		Installation site	In the altitude area of more than 1000 meters, due to the thin air caused by the poor heat dissipation effect of the inverter, it needs to be derated, and 1% derated for every 100m rise
	Temperature	-10℃ ~ + 50℃ , please reduce using at + 40℃ ~ +50℃	
	Humidity	5%RH~95%RH (non-condensation)	
	Vibration	Less than 5.9 m/s ² (0.6g)	
	Storage temperature	-20℃ ~ +60℃	
	Over voltage level	OVCIH	
	Class of contamination	PD2	
	Protection grade	IP20	
	Installation methods	Wall mounted	

Dimension Drawing

KC100 series inverter mechanical dimensions (mm)

Note: Please keep enough space when installing, the upper and lower space is recommended to keep >100mm, the left and right space is recommended to keep > 25mm

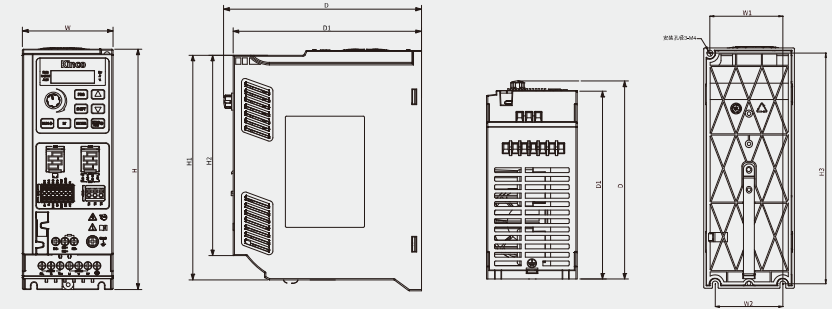

Voltage level	Model	Power (KW)	Dimension (mm)					Mounting hole location (mm)			Hole diameter of installation (mm)	Weight (kg)		
			W	H	H1	H2	D	D1	W1	W2			H3	
One-phase 220VAC	KC100-2S-0R40G/0R75L	0.4/0.75												0.85
	KC100-2S-0R75G/01R5L	0.75/1.5	65	177	168.5	145	148	139	50	45	168	3-M4		
Three-phase 380V/440VAC	KC100-4T/5T-0R75G/01R5L	0.75/1.5											0.90	
	KC100-4T/5T-01R5G/02R2L	1.5/2.2												

Voltage level	Model	Power (KW)	Dimension (mm)					Mounting hole location (mm)			Hole diameter of installation (mm)	Weight (kg)	
			W	H	H1	H2	D	D1	W1	W2			H3
One-phase 220VAC	KC100-2S-01R5G/02R2L	1.5/2.2											1.20
	KC100-2S-02R2G/03R7L	2.2/3.7											
Three-phase 380V/440VAC	KC100-4T/5T-02R2G/03R7L	2.2/3.7	75	199	190	166	163	156	60.5	56	191	3-M4	1.28
	KC100-4T/5T-03R7G/05R5L	3.7/5.5											
	KC100-4T/5T-05R5G/07R5L	5.5/7.5											

Terminal wiring diagram & Function description

KC100 series terminal wiring diagram

The power wiring diagrams of the three-phase and single-phase models are displayed in dotted lines. Connect cables according to the actual models

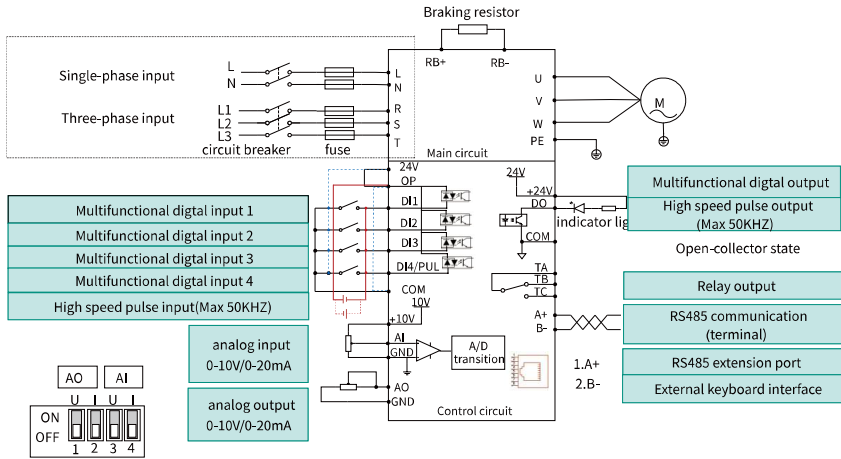

Note:
 1. DI1-DI4 can support NPN and PNP transistor signal input, bias voltage can be connected to the inverter internal power supply (+24V terminal) or external power supply (OP terminal)
 2. In the figure, black solid lines and blue dashed lines indicate two connection methods of DI1-DI4 connect to the internal power supply. red solid lines and red dashed lines indicate two connection methods of DI1-DI4 connect to the external power supply

KC100 series terminal function description

Terminal type	Terminal signal	Terminal name	Terminal function description
Main circuit	R/L, S, T/N	Three-phase/single-phase input terminals	Connect to the grid
	U, V, W	Three-phase output terminal	Three-phase AC output, connecting motor
	DC-	Negative end of DC	Common DC bus use
	DC+(RB+)	Dc bus plus end	
	RB-	Brake resistor wiring end	External brake resistor
Control circuit	OP	Multifunction input common terminal	The terminal is shorted with +24V by default. When DI1 to DI4 is driven by an external signal, the OP must be connected to the external power supply and disconnected from the +24V power supply terminal
	DI1-DI4	Multifunctional digital input	Compatible with bipolar input, support NPN and PNP connection, active level input voltage range: 9 ~ 30V, DI1-DI3 is low speed input, DI4 is used as a high speed input with a maximum input frequency of 50KHz.
	DO	High-speed pulse output	High speed pulse output; Max output frequency 50kHz, Also as an open collect output
	+24V	+24V	External 24VDC power supply; Output voltage range: 24V±10%; Maximum current: 200mA
	COM	24V power supply ground	Interior isolated from GND
	+10V	+10V analog voltage output	External 10V analog power supply; Output voltage range: 10V±10%; Maximum current: 10mA
	GND	Simulated ground	Interior isolated from COM
	AI	Analog input	Input voltage/current range: 0 ~ 10V/0 ~ 20mA; Select input signal type by dial switch
	AO	Analog output	Support 0 ~ 10V/0 ~ 20mA; Output select the output signal type through the dial switch
	TA-TB-TC	Relay output	Normally closed: TA-TB; Normally open: TA-TC
	A+	485 communication positive signal	RS485 communication, support standard MODBUS RTU protocol
B-	485 Communication negative signal		

Keyboard Operation

Keyboard operation

Support built-in keyboard and external keyboard, the body keyboard adopts 8 large-size independent keys, no multiplex keys, can avoid the possibility of mispressing easy and quick to achieve control functions, using potentiometer and external keyboard, keyboard cable up to 10 meters.

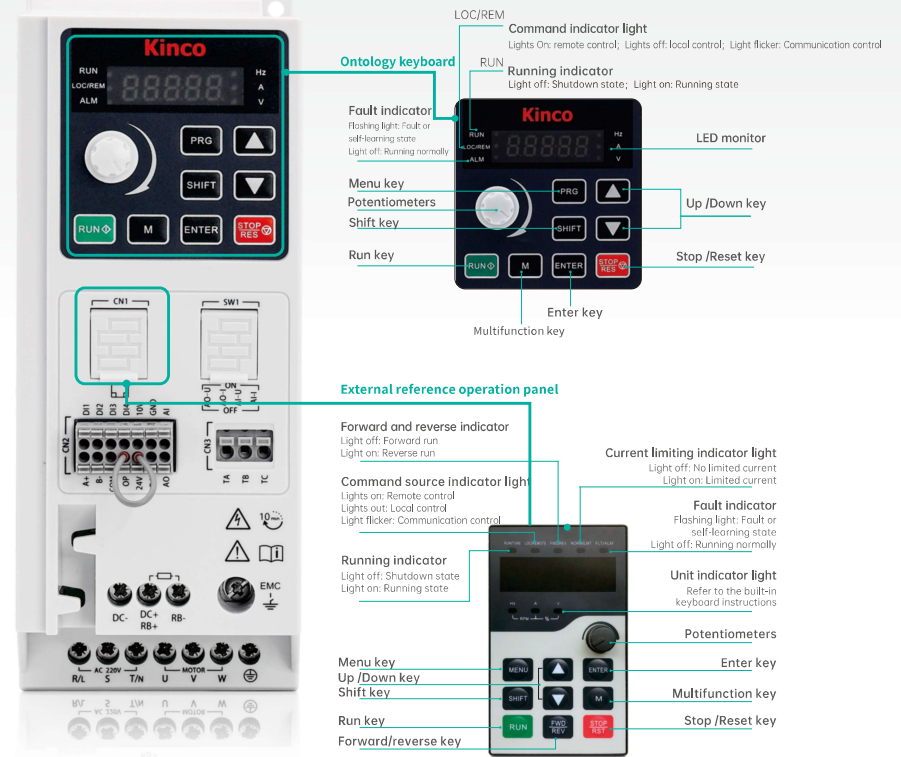

Name	Specification	Order number
External keyboard (without installation box)	NETKEY	19,0616
External keyboard (with installation box)	KC100_NETKEY	20,0207

EMC Filter selection

Model	Power (kW)	Specification	Rated current (A)	Order number
Single-phase 200V~240V 50Hz/60Hz				
KC100-2S-0R40G/0R75L	0.4/0.75	ME440-5	5	18.2.01.0216
KC100-2S-0R75G/01R5L	0.75/1.5	ME440-10	10	18.2.01.0215
KC100-2S-01R5G/02R2L	1.5/2.2	ME440-20	20	18.2.01.0214
KC100-2S-02R2G/03R7L	2.2/3.7	ME440-20	20	18.2.01.0214
Three-phase 380V~480V 50Hz/60Hz				
KC100-4T/5T-0R75G/01R5L	0.75/1.5	ME466-5	5	18.2.01.0211
KC100-4T/5T-01R5G/02R2L	1.5/2.2	ME466-5	5	18.2.01.0211
KC100-4T/5T-02R2G/03R7L	2.2/3.7	ME466-10	10	18.2.01.0212
KC100-4T/5T-03R7G/05R5L	3.7/5.5	ME466-10	10	18.2.01.0212
KC100-4T/5T-05R5G/07R5L	5.5/7.5	ME466-20	20	18.2.01.0213